

Commercial & Industrial

Energy Storage Solutions

FOR US MARKET



Renon Power USA LLC

Renon Power USA LLC. All Rights Reserved. Specifications are subject to change without notice.
2026-1-4



Renon Power



We Care About Sustainability

With our in-house R&D team and automated production gigafactories, we are dedicated to delivering innovative, reliable, and affordable energy storage solutions to customer globally.

At Renon, we believe that sustainable energy is the future. We are passionate about reducing carbon emissions and preserving our planet for future generations. That's why we invest heavily in research and development, leveraging the latest technologies to design and manufacture energy storage systems that are efficient, scalable, and adaptable.

Our products are designed to meet the needs of a wide range of applications, from residential and commercial buildings to industrial facilities and utility-scale projects. Whether you're looking to reduce your energy bills, increase your energy independence, or support your sustainability goals, Renon has the right solution for you.

Our commitment to quality and customer satisfaction is unwavering. We work closely with our clients to understand their unique needs and provide customized solutions that meet or exceed their expectations. We also provide comprehensive technical support, maintenance, and warranty services to ensure that our customers get the most out of their investment.

JOIN US ON OUR MISSION TO MAKE RENEWABLE ENERGY WITHIN REACH.

**PROVIDE INNOVATIVE,
RELIABLE, AND
AFFORDABLE ENERGY
STORAGE SOLUTIONS
TO CUSTOMERS
WORLDWIDE.**



Content

Meeting the highest standards of quality and safety in the global market.

Industry Application	01
Products	02
Renon EMS	37
Installation Cases	41
Renon Exhibition	42



Industry Application

Renon's energy storage products are extensively applied across residential, commercial, and industrial sectors. With exceptional performance, cutting-edge technology, and efficient energy management, they provide reliable, innovative, and eco-friendly energy solutions, helping global users achieve their sustainability goals.



Industrial
Manufacturing



Commercial
Retail



Commercial
Office Space

Commercial
Agriculture

Commercial
Data Centers

Commercial
Utilities



Industrial
Electricity Generating

Commercial
Supercharging Hub

Commercial
Logistics Park

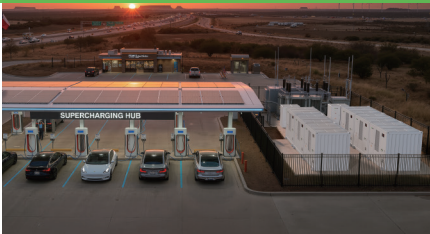

As a company that values renewable energy, we are passionate about developing solutions that contribute to a greener, more sustainable future. Our products are designed to reduce carbon emissions and promote environmental conservation.

Products

Our integrated C&I solutions offer autonomous energy storage and management for commerce and industry.

■ Small-Scale C&I Energy Storage



P03
ECube 60AP



P09
EBase 60B



P15
MPack 261AS

■ Distributed C&I Energy Storage



P19
MPack 261A



P23
Smart Matrix A

■ Battery-Buffered Fast Charging



P27
EStand

■ Portable BESS



P33
XGen



ECube 60AP

60kWh Air-Cooled Battery

The ultimate commercial and industrial energy storage solution with optimized temperature control, high-rate energy cycling, comprehensive fire and gas safety detection, and advanced integrated power management technologies.

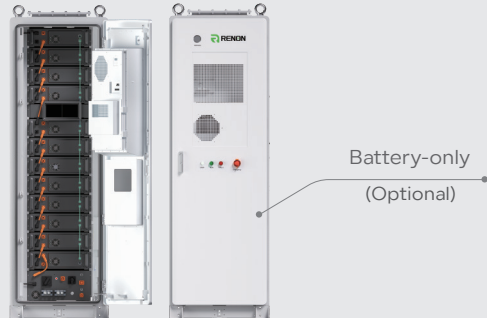

Product Function

- Efficient Energy Storage**
Stores 60kWh of electricity for future use, ensuring a stable energy reserve. It supports multiple energy inputs, including solar power, diesel generators, and the grid, providing flexible power integration.
- Smart Load Balancing**
Optimizes energy usage by charging during off-peak hours and discharging during peak demand, helping balance the grid load. By leveraging time-of-use pricing, it effectively reduces electricity costs.
- Intelligent Energy Management**
Utilizes an advanced Energy Management System (EMS) to optimize charging and discharging strategies. Remote monitoring and management capabilities enhance operational efficiency and system performance.

- Reliable Backup Power**
Acts as an emergency power source during grid failures, ensuring critical equipment remains operational. With uninterrupted power supply capabilities, it is ideal for data centers, hospitals, and other essential facilities.
- Independent Off-Grid Power**
Provides a reliable power supply in areas without grid access, making it suitable for homes, businesses, and communities. As a core component of microgrids, it ensures stable and efficient energy distribution.
- Scalable & Flexible Design**
Features a modular design that supports parallel system integration for expanded capacity. Its flexible configuration allows adjustments in power output and storage capacity to meet diverse energy needs.

Product Features

- High Energy Density**
Built with high-energy-density batteries, this system features a compact design, making it ideal for space-constrained environments. Its lightweight structure enhances ease of installation and transportation.
- Extended Lifespan**
Designed for longevity, it supports thousands of charge-discharge cycles with minimal degradation, ensuring stable long-term performance.

- High-Efficiency Power Conversion**
With superior charge and discharge efficiency, it minimizes energy loss while delivering millisecond-level response times to meet urgent power demands.
- Enhanced Safety & Reliability**
Equipped with multiple protection mechanisms, including safeguards against overcharging, over-discharging, overheating, and short circuits. Fire-resistant materials and flame-retardant design further enhance operational safety.

Application Scenario



Product Topology(For 480V System)

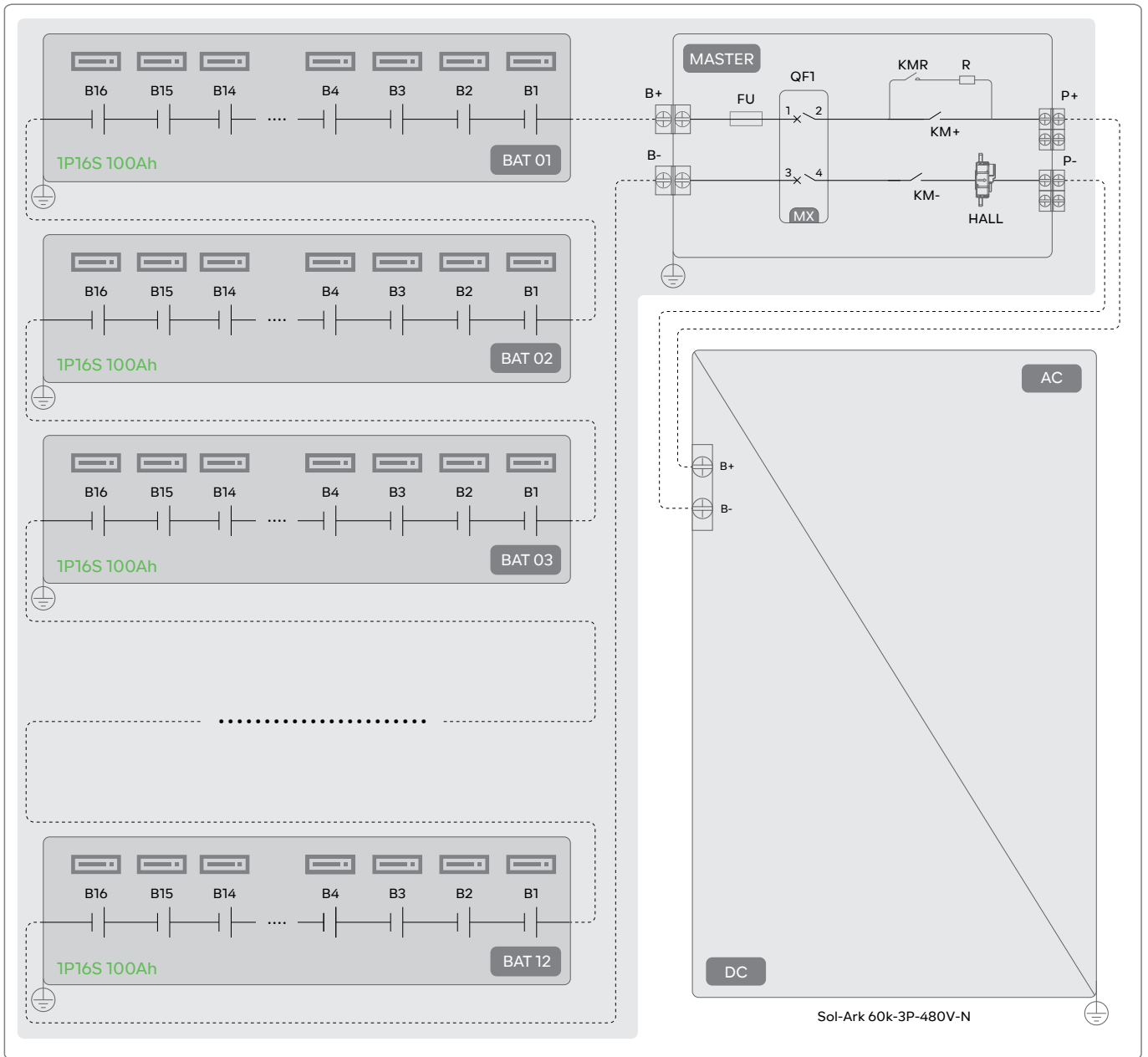

Packaging & Shipping Details

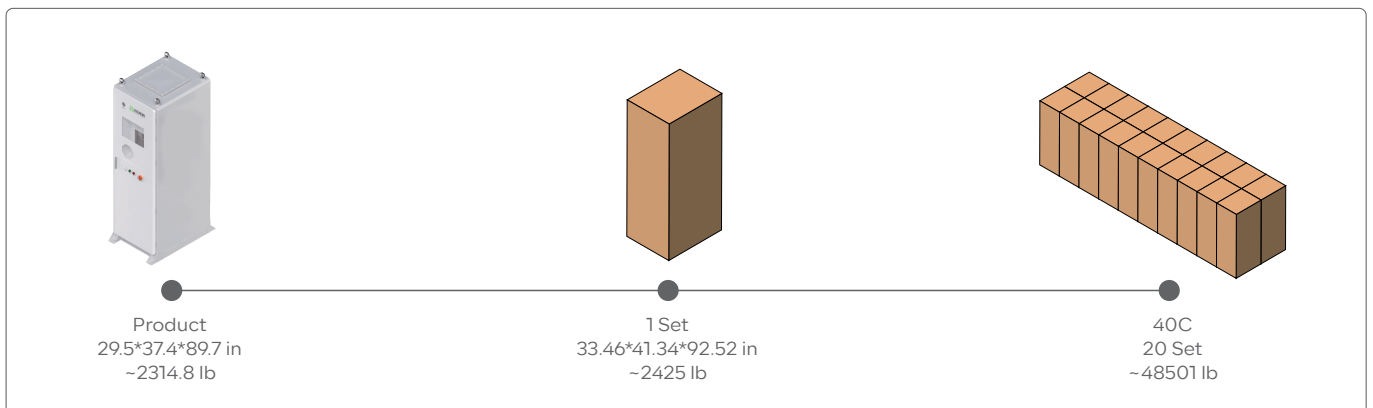

Product Topology (For 208V Application)

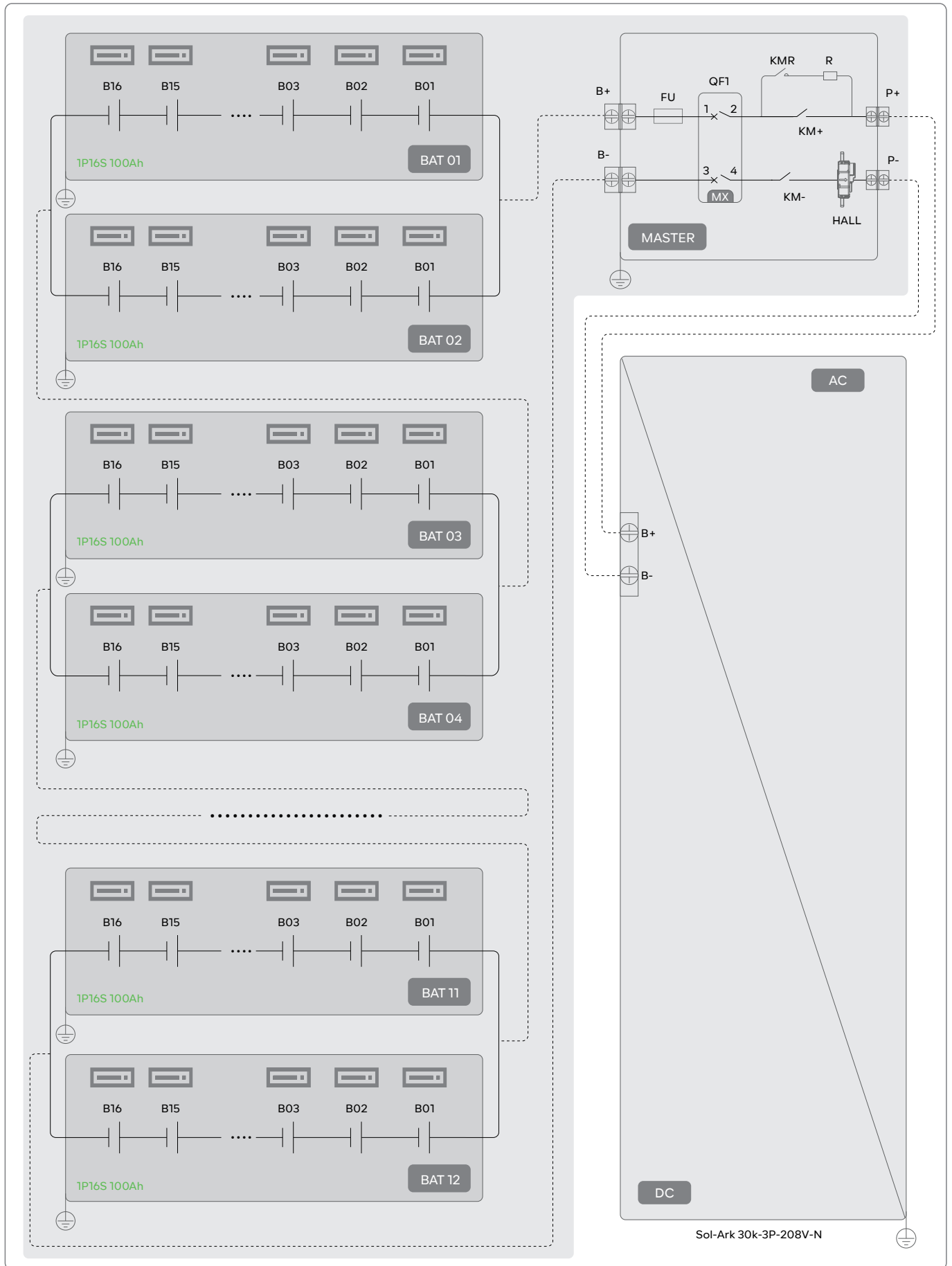

Single / Max. Parallel System Layout

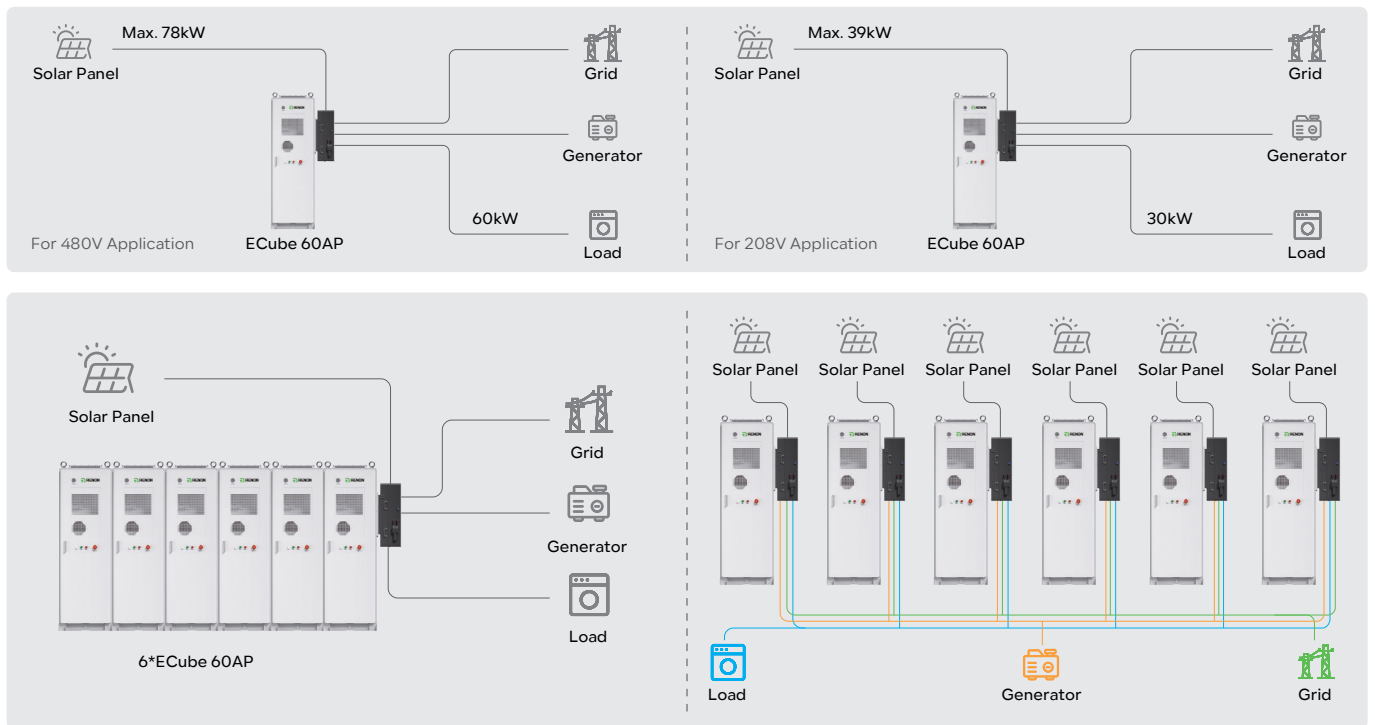

Energy Management System(EMS) Structure

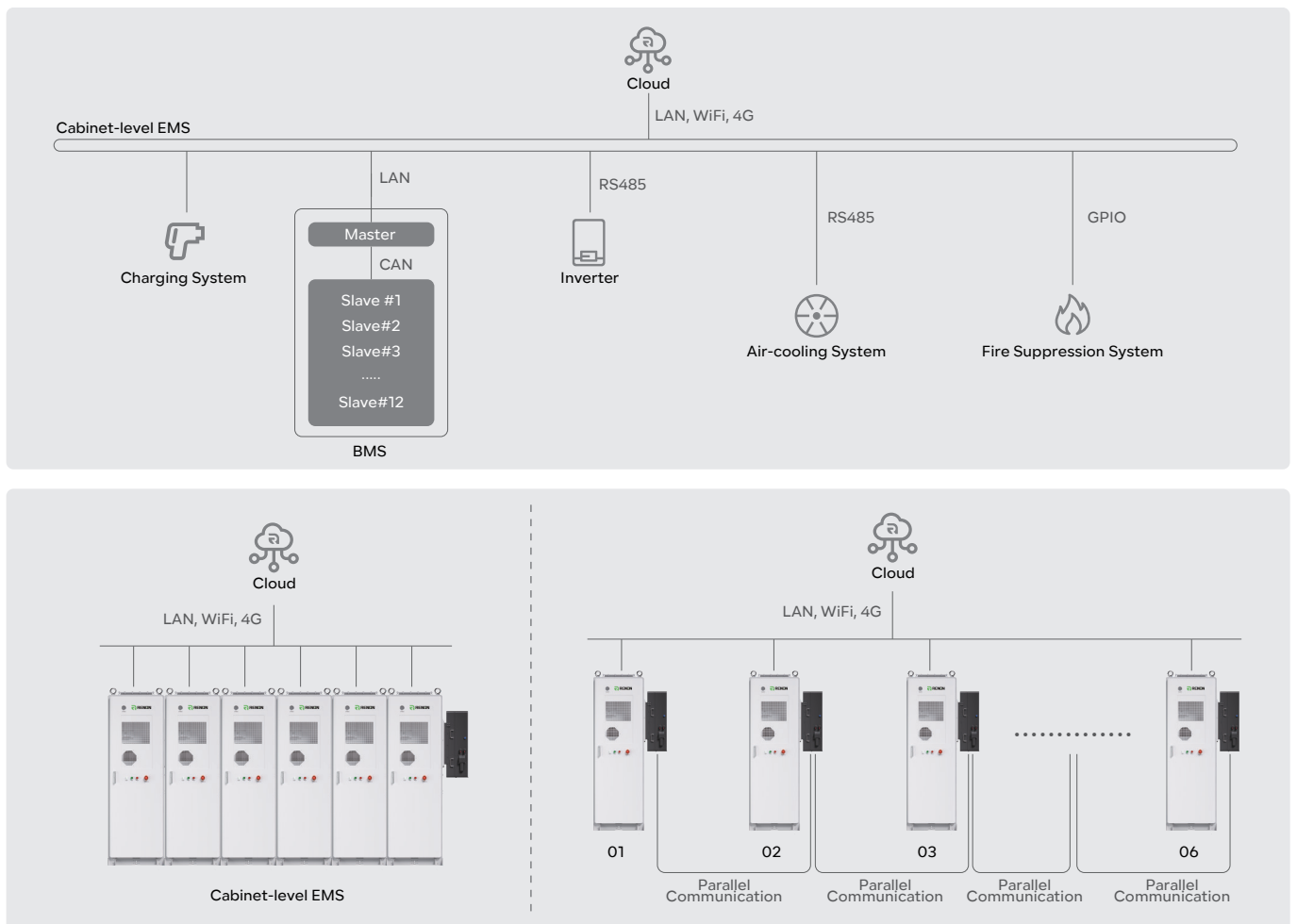

Product Parameter(For 480V Application)

Battery Energy Storage

Cell Chemistry	LiFePO4
Module Energy (kWh)	5.12
Module Nominal Voltage (V)	51.2
Module Capacity (Ah)	100
Battery Module Combination	12S1P
System Nominal Voltage (V)	614.4
System Operating Voltage (V)	562.5~681.6
System Energy (kWh)	61.44
Charge/Discharge Current (A)	95

PV Input

Max. Allowed PV Power (STC)(kW)	78
MPPT Voltage Range (V)	150~850
Start up Voltage (V)	180
Max. Input Voltage (V)	1000
Max. Operating Input Current per MPPT (A)	36
Max. Short Circuit Current per MPPT (A)	55
No. of MPP Trackers	4
No. of PV Strings per MPPT	2
Max. AC Coupled Input (kW)	60

Charging System(Optional)

Charging Type	Charging Mode 3 Case c, Level 2
Outlet Options	NACS (SAEJ3400) , AC Type 1 (SAEJ1772)
Input/Output Current Rating (A)	32 / 48 / 80
Input/Output Power Rating (kW)	19.2@240VAC
Input/Output Voltage (VAC)	480
Input Frequency (Hz)	50/60
Cable Length	16 feet, Optional: 25 feet
Distribution Systems	Single phase, split-phase
Connector Type	L1 + L2 + PE
Certifications	UL2594, UL2231-1, UL2231-2, UL1998 UL991FCC Part 15 Class B, ENERGY STAR

AC Output (EPS)

Nominal AC Voltage (3Φ)(V)	277/480
Grid Frequency (Hz)	50/60
Real Power, Max Continuous (3Φ)(kW)	60
Max. Output Current (A)	72.3
Peak Apparent Power (10s, off-grid, 3Φ)(kVA)	90
Max. Grid Passthrough Current (10min)(A)	200
Continuous Grid Passthrough Current (A)	180
Power Factor Output Range	±0.8 adjustable
Backup Transfer Time	5ms (adjustable)
CEC Efficiency	96.5%
Design (DC to AC)	Transformerless DC

General Parameters

Product Model	R-EC060060A1-US
System Scalability	Max. 6 System in Parallel
Battery Cabinet Dimension - W*D*H (in)	~29.5*37.4*91.3
Battery Cabinet Weight Approximate (lb)	~2358
Operation Temperature (°C/°F)	-30~55/-22~131
Communication Interface	CAN, RS485, WiFi, LTE
Humidity(RH)	0%~95%, non-condensation
Altitude	≤4000m/13122ft(2000m/6561ft derating)
IP Rating	IP55
Storage Temperature (°C/°F)	-20~35/-4~95
Recommend Depth of Discharge	90%
Cycle Life	>8000 cycles
Warranty	10 years
Certification (Battery)	ANSI/CAN/UL 1973:2022 ANSI/CAN/UL 9540:2020 UL 9540A, FCC Part 15 Subpart B:2023
Certification (Inverter)	UL 1741-2021 (UL1741SB) CSA C22.2 No 1071-16, IEEE 1547-2018 & 1547a-2020 & 1547.1-2020 (SRD V2.0) UL 1741 CRD-PCS, UL1699B, CEC, SGIP 4

Product Parameter(For 208V Application)

Battery Energy Storage

Cell Chemistry	LiFePO ₄
Module Energy (kWh)	5.12
Module Nominal Voltage (V)	51.2
Module Capacity (Ah)	100
Battery Module Combination	6S2P
System Nominal Voltage (V)	307.2
System Operating Voltage (V)	281.3~340.8
System Energy (kWh)	61.44
Charge/Discharge Current (A)	95

PV Input

Max. Allowed PV Power (STC)(kW)	39
MPPT Voltage Range (V)	150~500
Startup Voltage (V)	180
Max. Input Voltage (V)	550
Max. Operating Input Current per MPPT (A)	36
Max. Short Circuit Current per MPPT (A)	55
No. of MPP Trackers	4
No. of PV Strings per MPPT	2
Max. AC Coupled Input (kW)	30

Charging System(Optional)

Charging Type	Charging Mode 3 Case c, Level 2
Outlet options	NACS (SAEJ3400), AC Type 1 (SAEJ1772)
Input/Output Current Rating (A)	32 / 48 / 80
Input/Output Power Rating (kW)	7.7 / 11.5 @240VAC
Input/output voltage (VAC)	208
Input Frequency (Hz)	50/60
Cable Length	16 feet, Optional: 25 feet
Distribution Systems	Single phase, split-phase
Connector Type	L1 + L2 + PE
Certifications	UL2594, UL2231-1, UL2231-2, UL1998 UL991FCC Part 15 Class B, ENERGY STAR

AC Output (EPS)

Nominal AC Voltage (3Φ)(V)	120/208
Grid Frequency (Hz)	50 / 60
Real Power, Max continuous (3Φ)(kW)	30
Max. Output Current (A)	83.4
Peak Apparent Power (10s, off-grid, 3Φ)(kVA)	45
Max. Grid Passthrough Current (10min)(A)	200
Continuous Grid Passthrough Current (A)	180
Power Factor Output Range	±0.8 adjustable
Backup Transfer Time	5ms (adjustable)
CEC Efficiency	96.5%
Design (DC to AC)	Transformerless DC

General Parameters

Product Model	R-EC060030A1-US
System Scalability	Up to 6 in parallel
Battery Cabinet Dimension - W*D*H (in)	~29.5*37.4*91.3
Battery Cabinet Weight Approximate (lb)	~2358
Operation Temperature (°C/°F)	-30~55/-22~131
Communication Interface	CAN, RS485, WiFi, LTE
Humidity	0%~95%, non-condensation
Altitude	≤4000m/13122ft(2000m/6561ft derating)
IP Rating	IP55
Storage Temperature (°C/°F)	-20~35/-4~95
Recommend Depth of Discharge	90%
Cycle Life	>8000 cycles
Warranty	10 years
Certification(Battery)	ANSI/CAN/UL 1973:2022 ANSI/CAN/UL 9540:2020 UL 9540A, FCC Part 15 Subpart B:2023
Certification(Inverter)	UL 1741-2021 (UL1741SB) CSA C22.2 No 1071-16, IEEE 1547-2018 & 1547a-2020 & 15471-2020 (SRD V2.0) UL 1741 CRD-PCS, UL1699B, CEC, SGIP 4

EBase 60B

Rack-Mounted Indoor 60kWh Battery

The ultimate commercial and industrial energy storage solution, featuring optimized temperature control, high-rate energy cycling, and advanced power management. With a cost-effective pricing structure, it delivers exceptional value, ensuring reliability and efficiency for large-scale applications.



Product Function

- Efficient Energy Storage**
Stores 60kWh of electricity for future use, ensuring a stable energy reserve. It supports multiple energy inputs, including solar power, diesel generators, and the grid, providing flexible power integration.
- Smart Load Balancing**
Optimizes energy usage by charging during off-peak hours and discharging during peak demand, helping balance the grid load. By leveraging time-of-use pricing, it effectively reduces electricity costs.
- Intelligent Energy Management**
Utilizes an advanced Energy Management System (EMS) to optimize charging and discharging strategies. Remote monitoring and management capabilities enhance operational efficiency and system performance.

- Reliable Backup Power**
Acts as an emergency power source during grid failures, ensuring critical equipment remains operational. With uninterrupted power supply capabilities, it is ideal for data centers, hospitals, and other essential facilities.
- Independent Off-Grid Power**
Provides a reliable power supply in areas without grid access, making it suitable for homes, businesses, and communities. As a core component of microgrids, it ensures stable and efficient energy distribution.
- Scalable & Flexible Design**
Features a modular design that supports parallel system integration for expanded capacity. Its flexible configuration allows adjustments in power output and storage capacity to meet diverse energy needs.

Product Features

- High Energy Density**
Built with high-energy-density batteries, this system features a compact design, making it ideal for space-constrained environments. Its lightweight structure enhances ease of installation and transportation.
- Extended Lifespan**
Designed for longevity, it supports thousands of charge-discharge cycles with minimal degradation, ensuring stable long-term performance.

- High-Efficiency Power Conversion**
With superior charge and discharge efficiency, it minimizes energy loss while delivering millisecond-level response times to meet urgent power demands.
- Cost-Effective Solution**
Designed to deliver high performance at a lower cost, offering exceptional value without compromising on quality. By optimizing energy usage and minimizing maintenance needs, this solution helps reduce operational expenses and maximize long-term savings.

Application Scenario



Product Parameter(For 480V Application)

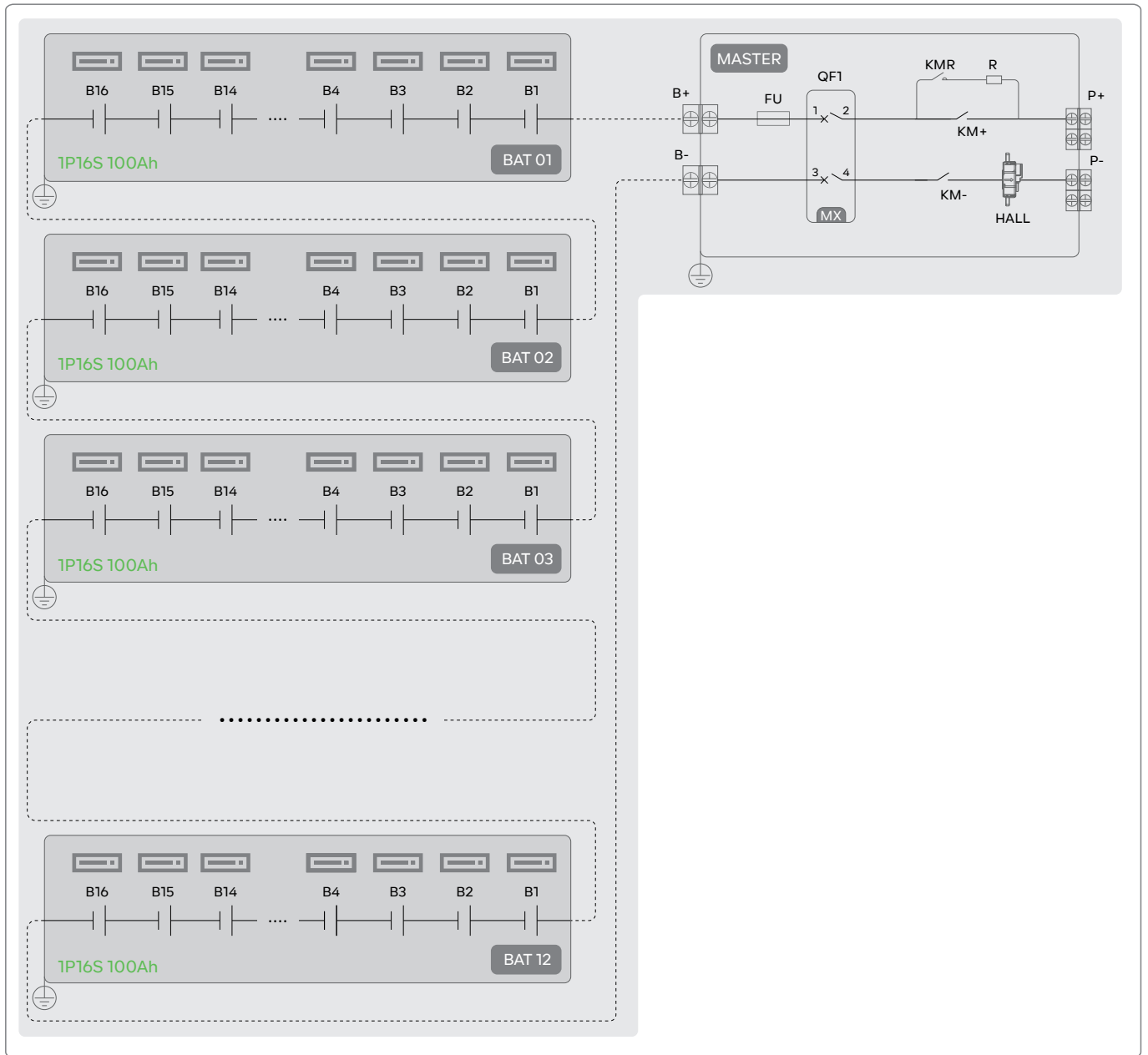

Packaging & Shipping Details

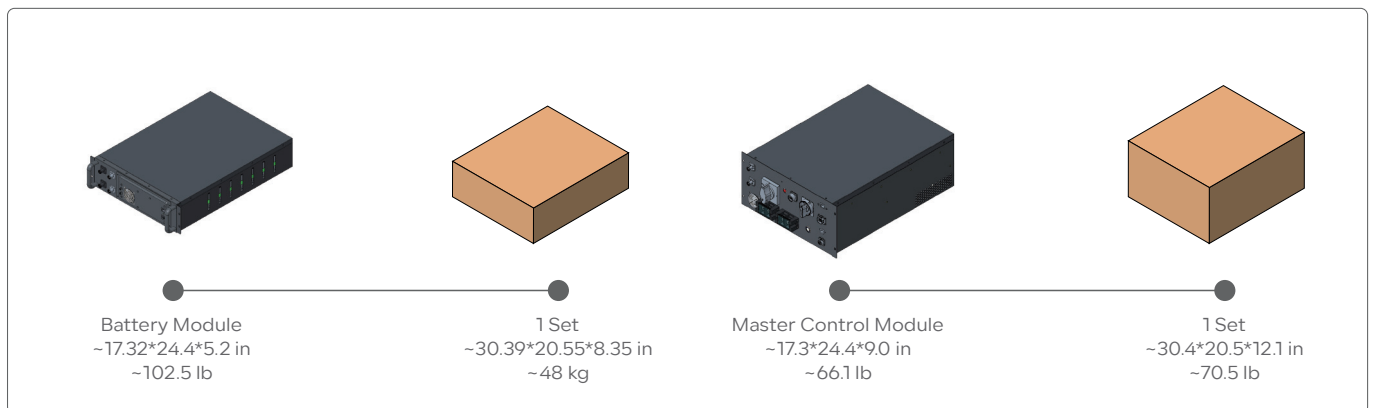

Product Topology (For 208V Application)

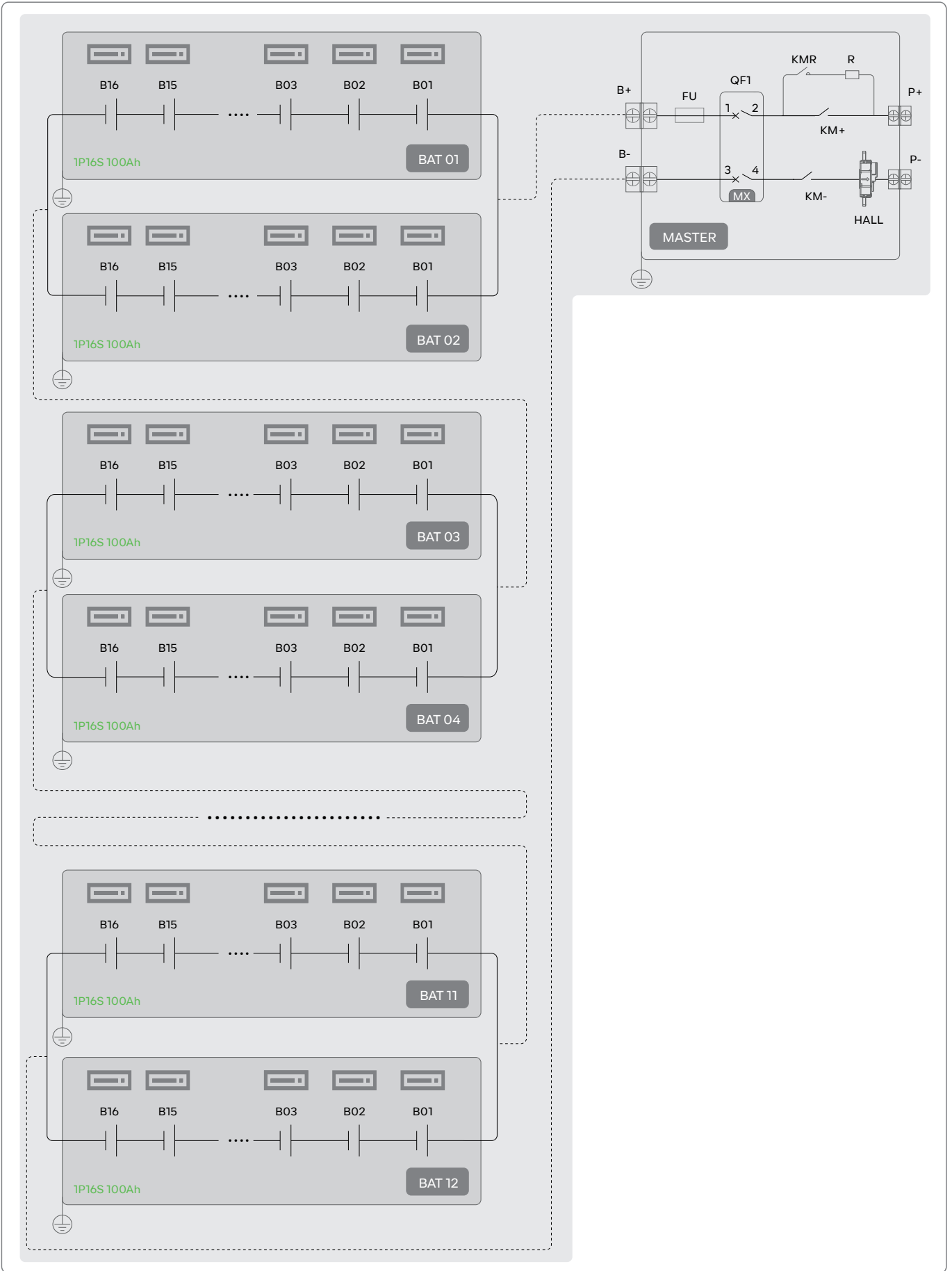

Single / Max. Parallel System Layout

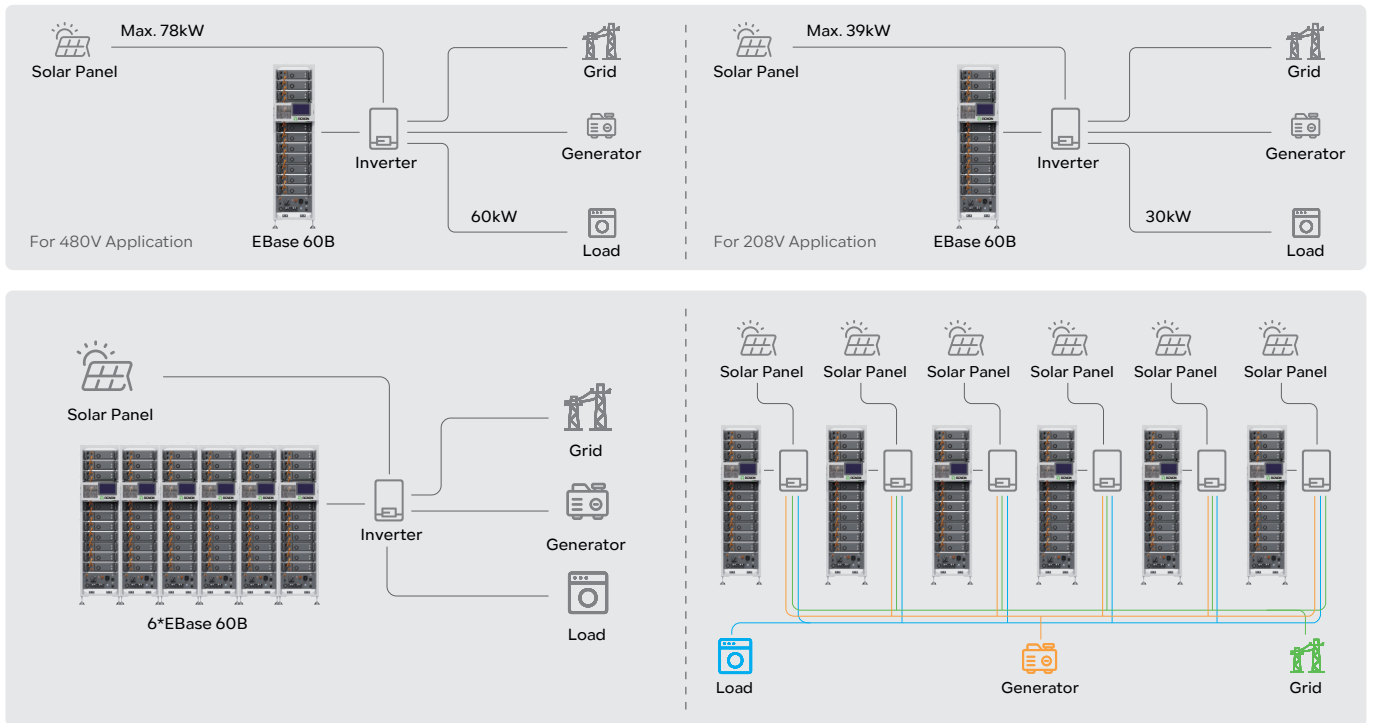

Energy Management System(EMS) Structure

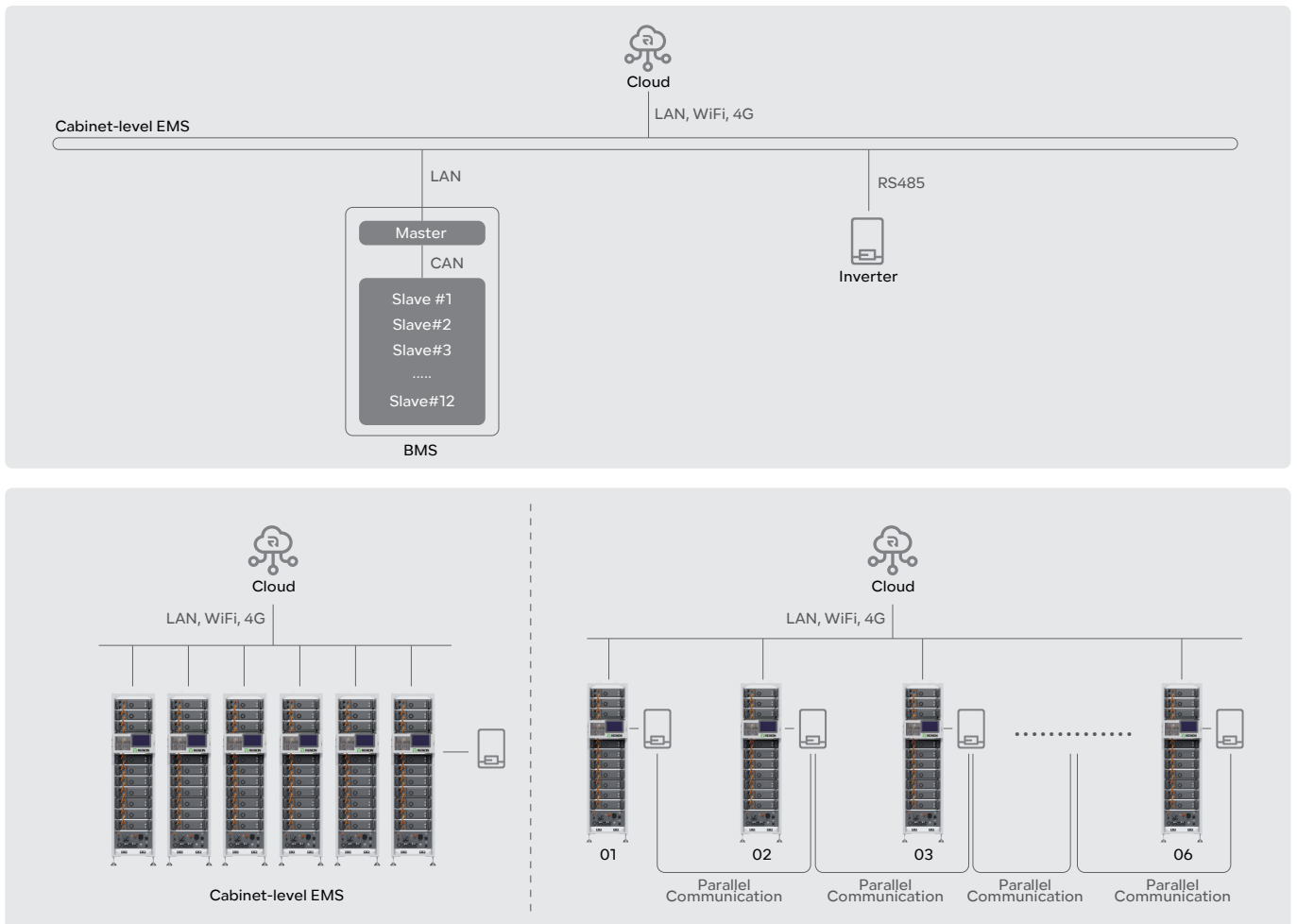

■ Product Parameter(For 480V Application)

Battery Energy Storage	
Cell Chemistry	LiFePO4
Module Energy (kWh)	5.12
Module Nominal Voltage (V)	51.2
Module Capacity (Ah)	100
Battery Module Combination	12S1P
System Nominal Voltage (V)	614.4
System Operating Voltage (V)	562.5~681.6
System Energy (kWh)	61.44
Charge/Discharge Current (A)	95

General Parameters	
Product Model	R-EB060LCB01-US
System Scalability	Max. 6 System in Parallel
Dimension - W*D*H (in)	~21.38*30.43*85.79
Weight Approximate (lb)	~1500
Operation Temperature (°C/°F)	-30~55/-22~131
Communication Interface	CAN, RS485, WiFi, LTE
Humidity(RH)	5%~85%, non-condensation
Altitude	≤4000m/13122ft(2000m/6561ft derating)
IP Rating	IP20
Storage Temperature (°C/°F)	-20~35/-4~95
Recommend Depth of Discharge	90%
Cycle Life	>8000 cycles
Warranty	10 years
Certification	ANSI/CAN/UL 1973:2022, ANSI/CAN/UL 9540:2020, UL 9540A, FCC Part 15 Subpart B:2023

■ Product Parameter(For 208V Application)

Battery Energy Storage	
Cell Chemistry	LiFePO4
Module Energy (kWh)	5.12
Module Nominal Voltage (V)	51.2
Module Capacity (Ah)	100
Battery Module Combination	6S2P
System Nominal Voltage (V)	307.2
System Operating Voltage (V)	281.3~340.8
System Energy (kWh)	61.44
Charge/Discharge Current (A)	95
General Parameters	
Product Model	R-EB060LCB02-US
System Scalability	Max. 6 System in Parallel
Dimension - W*D*H (in)	~21.38*30.43*85.79
Weight Approximate (lb)	~1500
Operation Temperature (°C/°F)	-30 ~ 55/ -22 ~ 131
Communication Interface	CAN, RS485, WiFi, LTE
Humidity(RH)	5%~85%, non-condensation
Altitude	≤4000m/13122ft(2000m/6561ft derating)
IP Rating	IP20
Storage Temperature (°C/°F)	-20 ~ 35/ -4 ~ 95
Recommend Depth of Discharge	90%
Cycle Life	>8000 cycles
Warranty	10 years
Certification	ANSI/CAN/UL 1973:2022, ANSI/CAN/UL 9540:2020, UL 9540A, FCC Part 15 Subpart B:2023

MPack 261AS

261kWh Liquid-cooled Battery

The MPack 261AS stores 261 kWh of electricity, supporting flexible integration with solar, diesel, and grid power. Its modular design allows for easy expansion, while intelligent energy management and remote monitoring optimize system performance. Up to six units can be paralleled for seamless grid transfer within 20 ms.

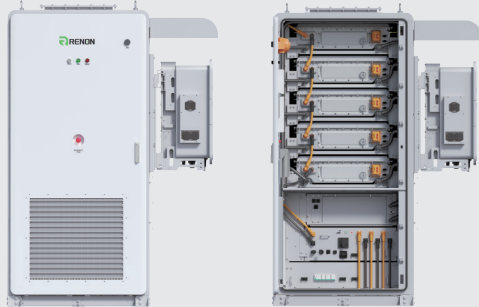

Product Function



Efficient Energy Storage

Stores 261kWh of electricity for future use, ensuring a stable energy reserve. It supports multiple energy inputs, including solar power, diesel generators, and the grid, providing flexible power integration.



Scalable & Flexible Design

Features a modular design that supports parallel system integration for expanded capacity. Its flexible configuration allows adjustments in power output and storage capacity to meet diverse energy needs.



Smart Multi-Source Inputs

Intelligent ports accept multiple power sources—including grid-tied inverters, generators, and wind turbines—and coordinates them for stable, efficient operation.



Intelligent Energy Management

Utilizes an advanced Energy Management System (EMS) to optimize charging and discharging strategies. Remote monitoring and management capabilities enhance operational efficiency and system performance.



AC and DC-Coupled PV for Flexible Expansion

Supports both AC and DC PV coupling, enabling easy scalability and retrofits without major system rework.



Up to 6 Units AC-Parallel

Parallel up to six systems on the AC side and achieve seamless transfer to/from the grid in approximately 20 ms to keep critical loads online.

Product Features

Up to 200% PV Oversizing

Maximizes solar harvest and utilization, enabling higher yield in low-irradiance hours without major system changes.

High-Efficiency Power Conversion

With superior charge and discharge efficiency, it minimizes energy loss while delivering millisecond-level response times to meet urgent power demands.

160% / 200 ms Off-Grid Overload for Reliable Starts

Delivers short-burst headroom to handle inrush current, ensuring smooth startup of motors and water pumps without nuisance trips.

Enhanced Safety & Reliability

Equipped with multiple protection mechanisms, including safeguards against overcharging, over-discharging, over heating, and short circuits. Fire-resistant materials and flame-retardant design further enhance operational safety.

Application Scenario



Product Topology

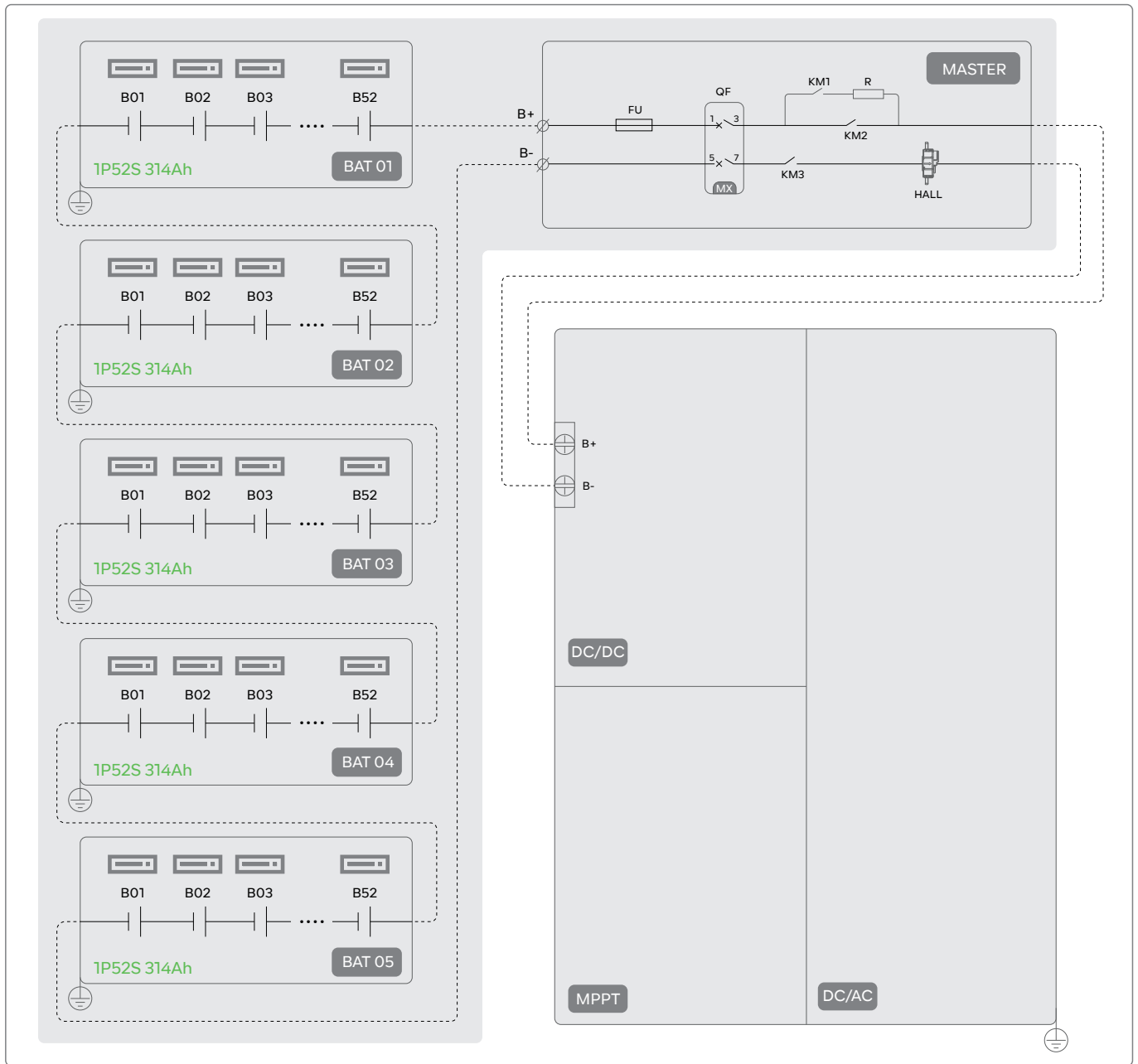

Packaging & Shipping Details

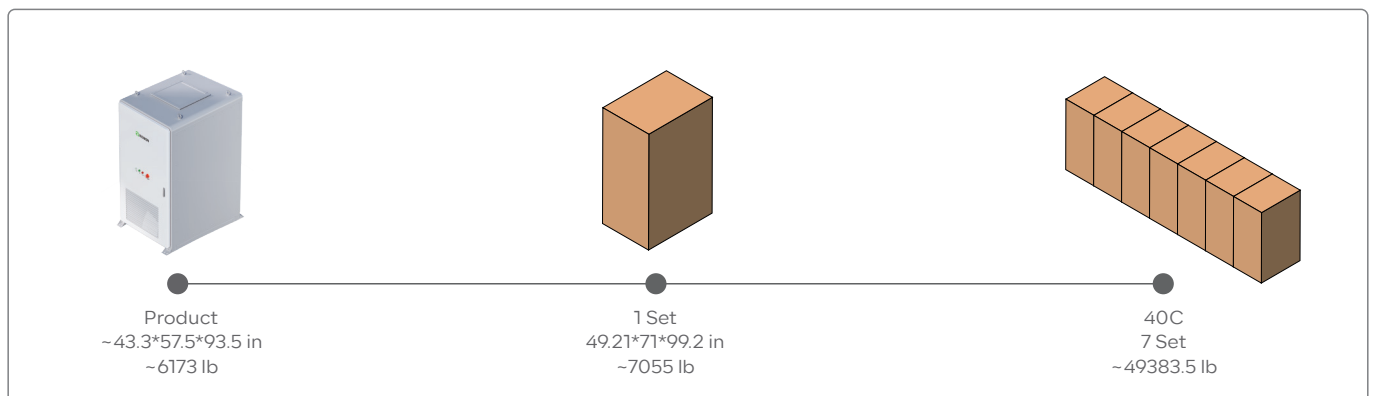

Single / Max. Parallel System Layout

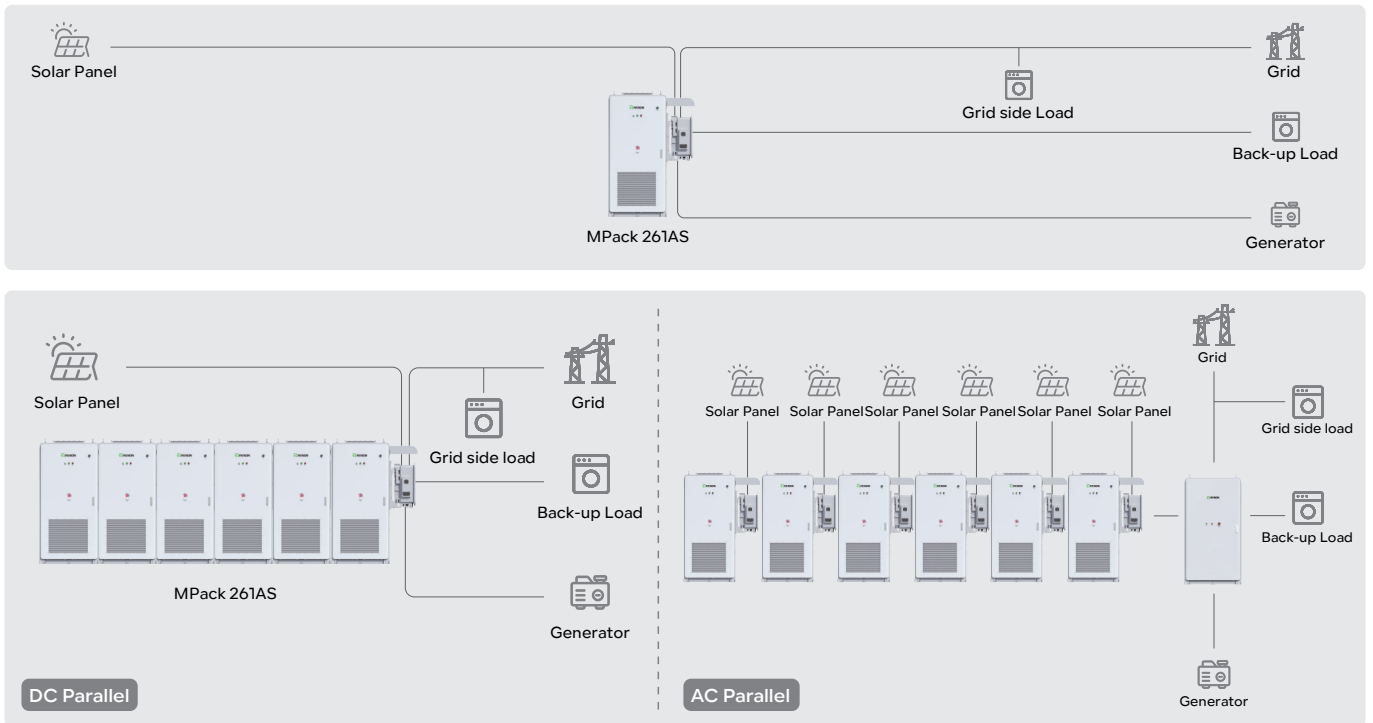

Energy Management System(EMS) Structure

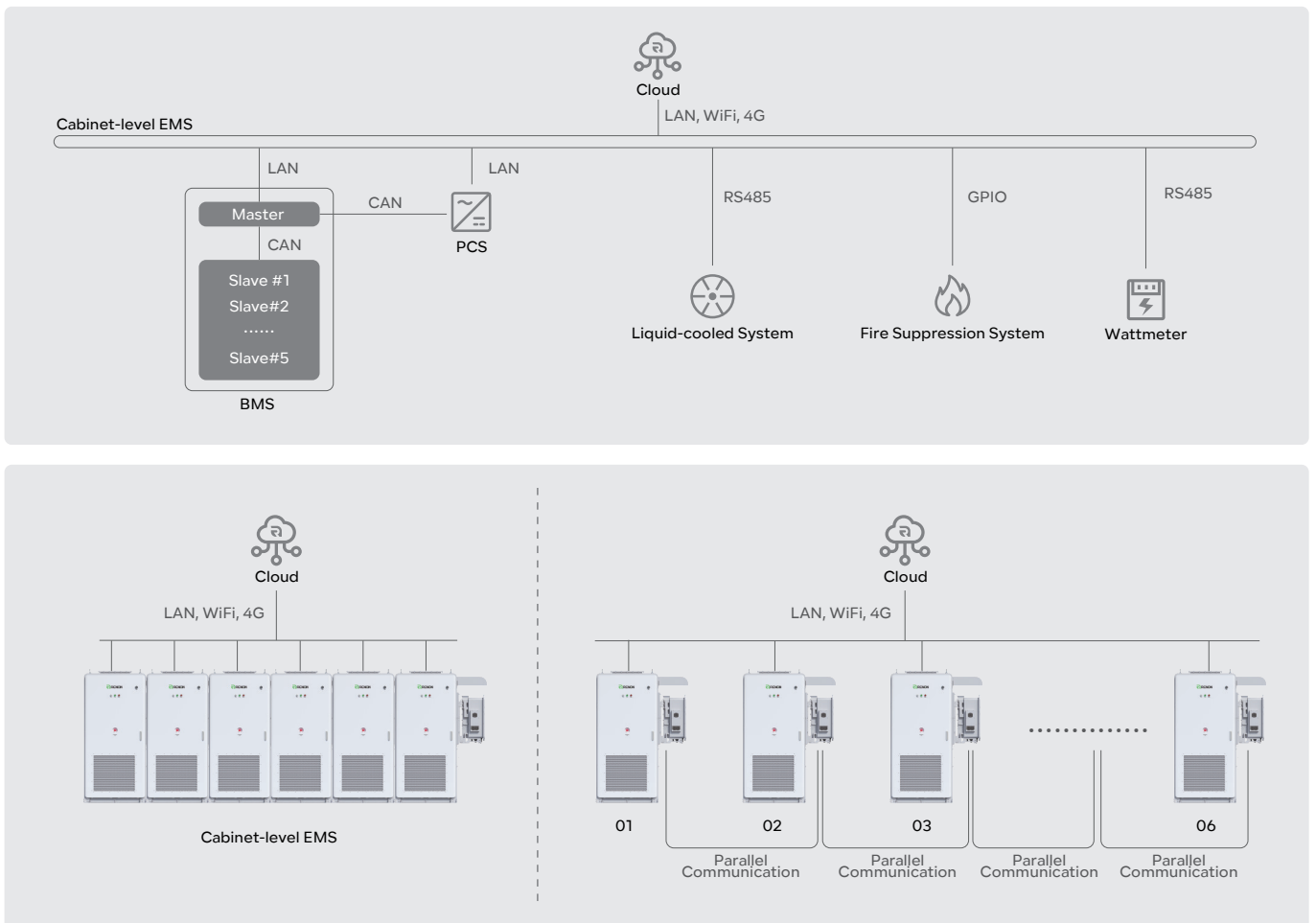

Product Parameter

Battery Energy Storage	
Cell Type	LFP 3.2V/314Ah
Module configuration	1P52S
System Combination (Modules)	5 in series
Capacity (kWh)	261.2
Nominal Voltage (V)	832
Operation Voltage Range (VDC)	702-936
Discharge Depth	90% DoD
Thermal Management Mode	Liquid-cooled
Thermal Control Management	Aerosol Extinguishing

PV Input	
Recommended Max. PV array size (kW)	250
Max. Usable PV Input Power (kW)	250
Max. Input Voltage (V)	1000
Rated Voltage (V)	600
Start-up Voltage (V)	180
MPPT Voltage Range (V)	150 ~ 950
Max. Input Current (A)	10*42
Max. Short Circuit Current (A)	10*60
MPPT Number / Max. Input Strings Number	10/20

AC Output (Grid Side)	
Rated Output Power (kW)	125
Max. Apparent Output Power (kVA)	125
Rated Grid Voltage	3/N/PE, 277 V / 480 V
Rated Grid Frequency (Hz)	50 / 60
Rated Grid Output Current (A)	150
Power Factor	> 0.99 (0.8 leading - 0.8 lagging)
THDi	< 3%

AC Output (Back-up)	
Rated Output Power (kW)	125
Max. Apparent Output Power	1.2 times of rated power, 100s 1.4 times of rated power, 10s 1.6 times of rated power, 200ms
Back-up Switch Time (Ms)	< 10
Rated Output Voltage	3/N/PE, 277V / 480 V
Rated Frequency (Hz)	50 / 60
Thdv (@linear Load)	< 2%

AC Input (Generator)	
Max. Input Power (kW)	125
Rated Input Current (A)	150
Rated Input Voltage	3/N/PE, 277 V / 480 V
Rated Input Frequency (Hz)	50 / 60

System Characteristic	
Communication Interface	CAN, RS485, Ethernet
Warranty	5 years free, paid from the 6th to the 15th year
Certifications	ANSI/CAN/UL1973:2022 ANSI/CAN/UL9540:2023, UL9540A:2025 UL1741:2012 Ed.3+R:19May2023 UL1741:2021 Ed.3(Supplement SB) CSA C22.2#1071:2016 Ed.4+U1 IEEE 1547:2018, IEEE 1547:2020

General Parameters	
Battery Model	R-MPS261125A1-US
Dimensions - W*D*H (in)	~43.3*57.5*93.5 (±0.5)
Total Weight (lb)	~6173 (±5%)
Max. Count of Grid-tie & islanding transitions	6
Grid-connected & Off-grid Switching Time	≤20mS
Operation Altitude	≤4000m/13122ft (2000m/6561ft derating)
Noise Level @1m	<75 dB(A)
IP Rating	IP54
Operating Temperature (°C/°F)	-25~55°C/-13~131°F
Operating Humidity (RH)	0 to 95%, non-condensation
Storage Conditions	-20~30°C/-4~86°F Up to 95% RH, non-condensation State of Energy (SoE): 50% initial

MPack 261A

261kWh Liquid-cooled Battery

MPack 261A is a high-performance all-in-one energy storage solution for commercial and industrial use, featuring optimized thermal management, efficient energy cycling, advanced fire and gas detection, and intelligent power management for reliable and scalable energy integration.

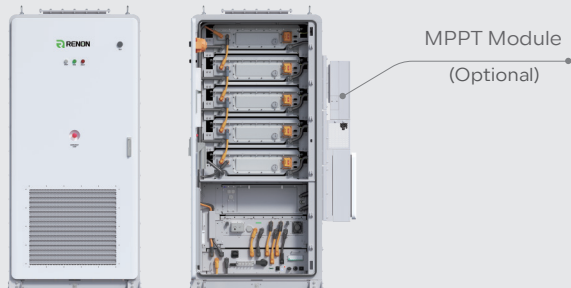

Product Function



Advanced Energy Storage

Stores 261kWh of electricity for future use, ensuring a reliable energy reserve. It supports integration with multiple power sources, including solar energy, diesel generators, and the grid, offering versatility in energy input.



Smart Load Management

Balances grid demand by charging during off-peak hours and discharging during peak hours, optimizing energy distribution. By leveraging time-of-use pricing, it helps reduce electricity costs and enhance overall energy efficiency.



Intelligent Energy Management

Optimizes charging and discharging efficiency through an advanced Energy Management System (EMS). With remote monitoring and real-time control capabilities, it enhances operational oversight and improves energy utilization.



Reliable Backup Power

Provides a dependable backup power supply during grid failures, keeping critical equipment operational. With seamless, uninterrupted power delivery, it is ideal for mission-critical applications such as data centers and hospitals.



Independent Off-Grid Power

Delivers a stable power supply to homes, businesses, or communities in off-grid areas, enabling independent operation. As a key component of microgrid systems, it ensures efficient and reliable energy distribution.



Scalable & Flexible Design

Features a modular design that supports parallel system integration for seamless capacity expansion. Its customizable configuration allows adjustments in power output and storage capacity to meet specific energy demands.

Product Features

High Energy Density

Designed with high-energy-density 1P52S 314Ah batteries, this system offers a compact size, making it ideal for space-constrained environments. Its optimized structure reduces weight, enhancing ease of installation and transportation.

Long Lifespan

Designed for longevity, it supports over 8000 charge-discharge cycles with minimal degradation, ensuring stable long-term performance.

High-Efficiency Conversion

With superior charge and discharge efficiency and a charge/discharge current of 150A, it minimizes energy loss while delivering millisecond-level response times to meet urgent power demands.

Safe & Reliable

Equipped with multiple protection mechanisms, including safeguards against overcharging, over-discharging, overheating, and short circuits. With an IP54 protection rating, fire-resistant materials, and a flame-retardant design, it further enhances operational safety.

Application Scenario



Product Topology

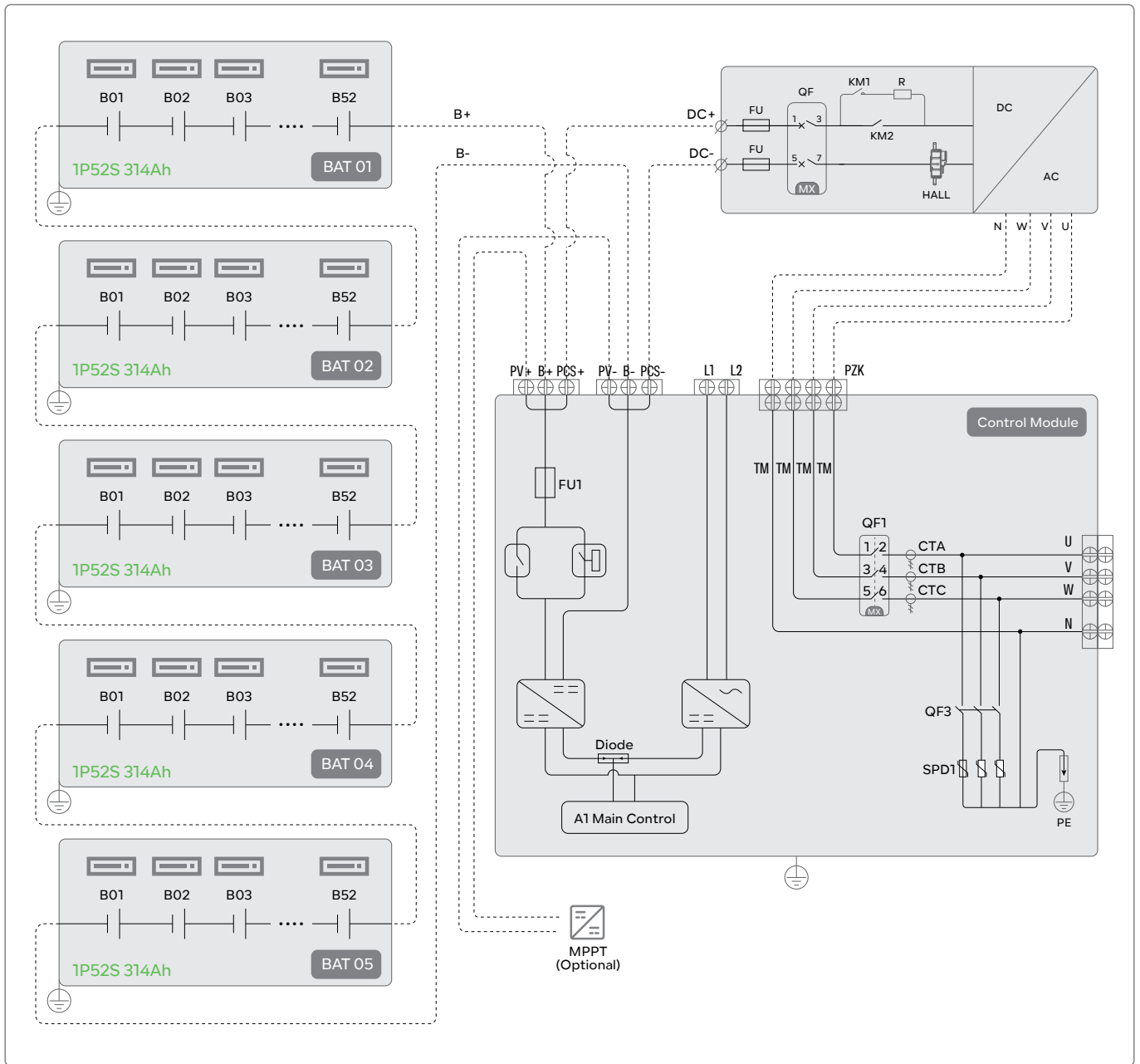

Packaging & Shipping Details

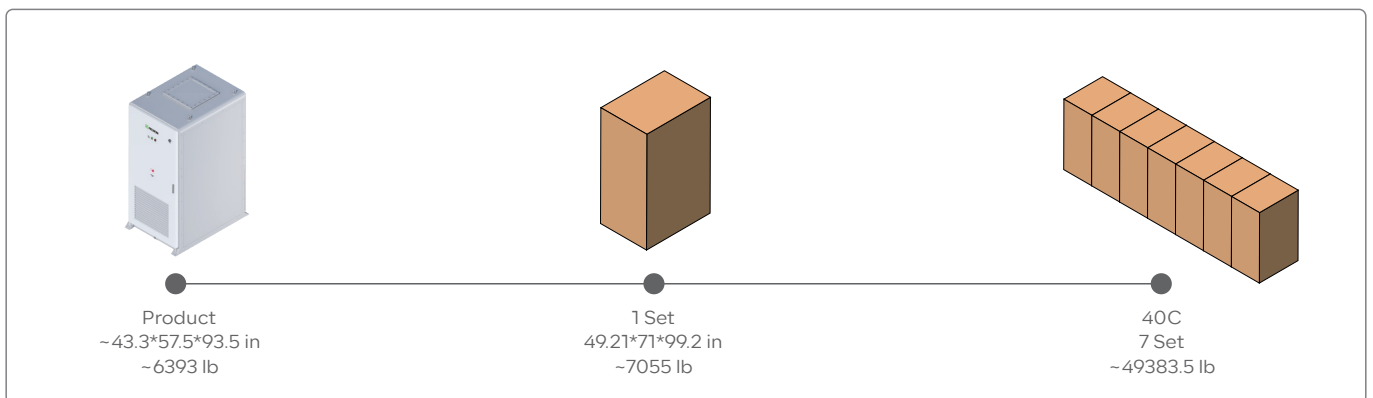

On/Off-grid System Layout

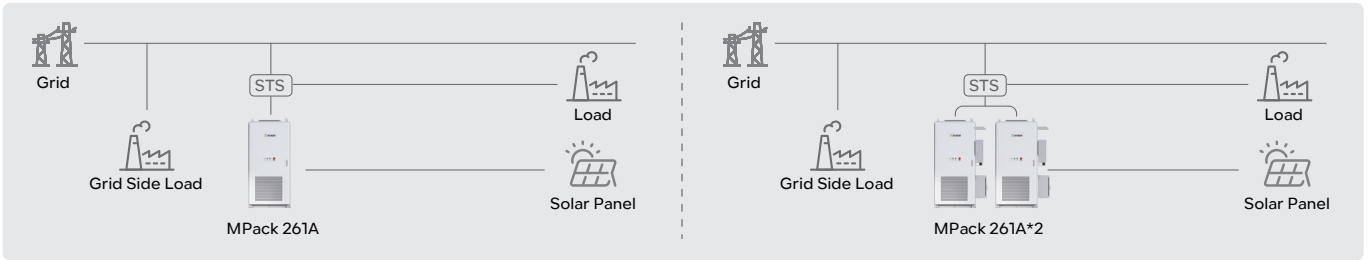

*Max. support for two units in on/off-grid switching; switching time ≤ 20 ms.

On-grid System Layout

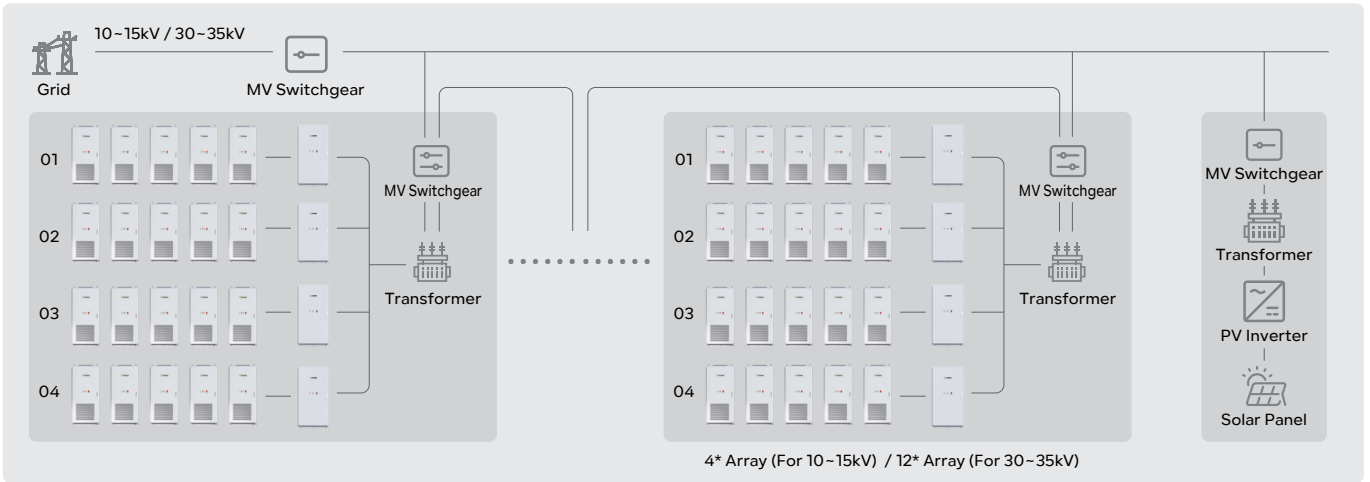

*PV AC coupling

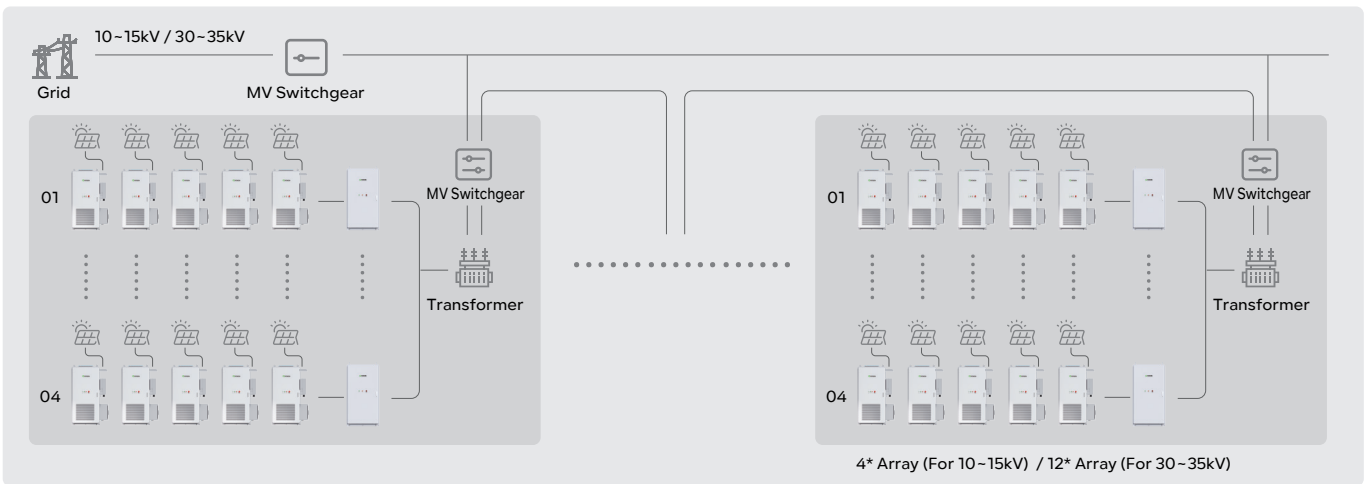

*PV DC coupling

Energy Management System(EMS) Structure

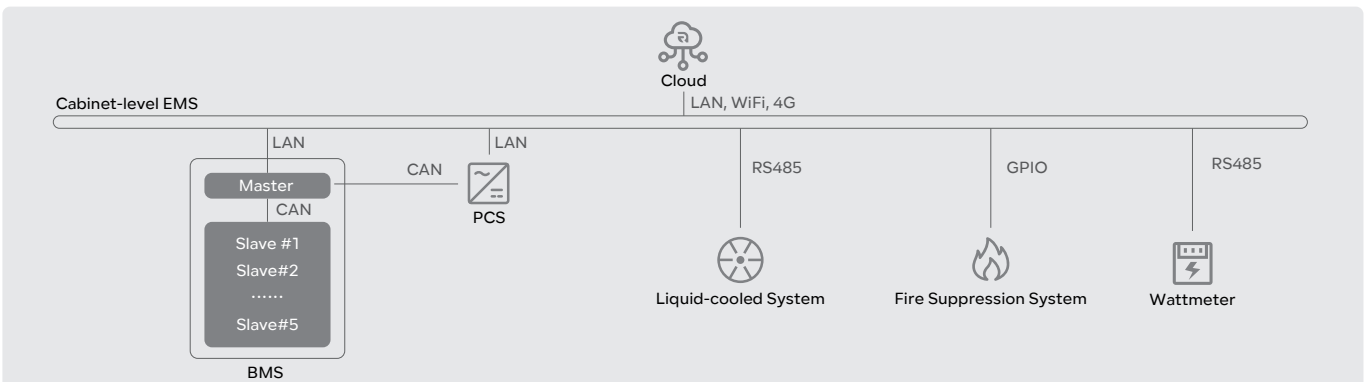

Product Parameter

Battery Energy Storage

Cell Type	LFP 3.2V/314Ah
Module configuration	1P52S
System Combination (Modules)	5 in series
Capacity (kWh)	261.2
Nominal Voltage (V)	832
Operation Voltage Range (Vdc)	702~936
Discharge Depth	90% DoD
Thermal Management Mode	Liquid-Cooled
Thermal Control Management	Aerosol Extinguishing

AC Output

Rated AC Output Power (kW)	135
Max.AC Output Power (kVA)	148.5
Rated Output Voltage (Vac)	480
Output Voltage Range (Vac)	408~528
Rated Grid Frequency (Hz)	60(-5~5)Hz
Adjustable Power Factor	0.99/-1~1
THDi	≤3%

DC Input/Output

Max. Power (kW)	270
Voltage Range (V)	702~936
Max. Current(A)	314

System Characteristic

Max. Count of Grid-tie & Islanding Transitions	2 (Optional STS)
Grid-connected & Off-grid Switching Time	≤20mS
Communication Interface	CAN, RS485, Ethernet
Warranty	5 years free, paid from the 6th to the 15th year
Certifications	ANSI/CAN/UL1973:2022, ANSI/CAN/UL9540:2020 UL9540A:2019, UL1741:2012 Ed.3+R:19May2023 UL1741:2021 Ed.3(Supplement SB) CSA C22.2#1071:2016 Ed.4+U1 IEEE 1547:2018,IEEE 15471:2020

General Parameters

Battery Model	R-MP261135A1-US
Dimensions - W*D*H (in)	~43.3*57.5*93.5 (±0.5)
Total Weight (lb)	~6393 (±5%)
Operation Altitude	≤4000m/13122ft (2000m/6561ft derating)
Noise Level @1m	<75 dB(A)
IP Rating	IP54
Operating Temperature (°C/°F)	-30~55/-22~131
Operating Humidity (RH)	0 to 95%, non-condensation
Storage Conditions	-20~30°C/-4~86°F Up to 95% RH, non-condensation State of Energy (SoE): 50% initial

Smart Matrix A

10ft Battery & Boost Converter One Stop Solution

Combiner Cabinet Communication Cabinet



Product Function



BMS Battery Management System

The BMS ensures safe and efficient operation of the battery by monitoring key parameters such as voltage, temperature, and charge/discharge status. It helps to extend battery life, improve performance, and prevent issues like overcharging or overheating.



EMS Energy Management System

The EMS optimizes energy flow within the system, dynamically adjusting charging and discharging strategies based on demand and grid conditions. It enhances efficiency, reduces energy costs, and integrates with grid systems for stable power management.



UPS Uninterruptible Power Supply

The UPS function ensures continuous power during grid failures or disruptions, maintaining stable operation of critical equipment like data centers or communication stations, thus enhancing system reliability.



Highly Integrated Design

Smart Matrix A combines core components including PCS, battery system, and the BMS into a single unit. This reduces the need for external connections, saving installation space and costs. Its modular architecture supports flexible capacity expansion to meet varying energy storage demands.



Multi-Unit Parallel Operation

Smart Matrix A supports multi-unit parallel operation, enabling scalable capacity expansion. This feature ensures flexibility and reliability, making it suitable for both small and large-scale projects.



Fire Protection

Equipped with advanced fire protection features, including temperature control and fire detection systems, Smart Matrix A ensures safety by automatically activating emergency measures in case of abnormal conditions, minimizing fire risks.

Product Features

High Integration

The liquid-cooled system battery box offers the highest capacity with the latest dimensions, requiring minimal space while providing flexible transportation and installation options.

Efficient and Flexible

Featuring a modular structure and an efficient liquid cooling system, it is designed to perform well in extreme environments, maximizing battery lifespan and performance.

Safety and Reliability

Equipped with comprehensive battery monitoring, multi-layer fire prevention, top ventilation design, and active AI management to ensure maximum safety and reliability.

Smart Operation and Maintenance

Comes with a complete EMS that is easy to upgrade, featuring big data management checks, proactive handling, and intelligent SOC calibration to ensure optimal performance with zero downtime.

Application Scenario



Product Topology

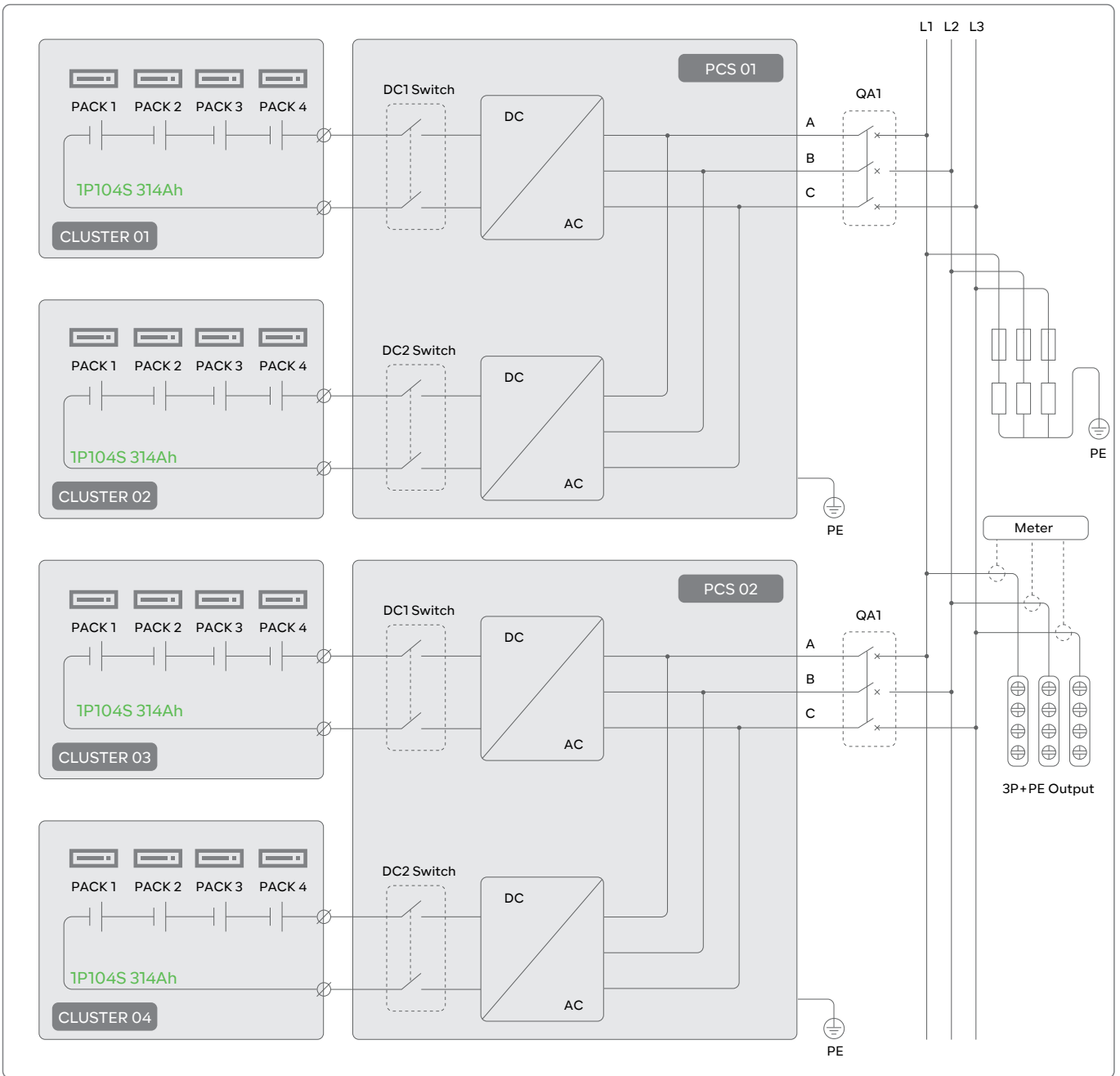

Packaging & Shipping Details

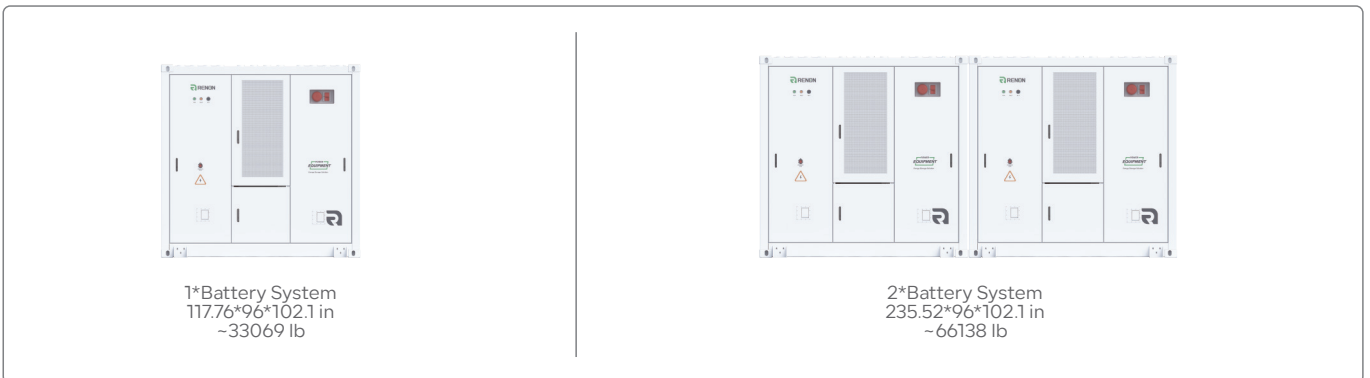

■ BESS Parameter

Battery Energy Storage	1672kWh	3344kWh	5016kWh
Cell Type	LFP 3.2V/314Ah		
Module Configuration	1P104S		
String Configuration	1P416S		
Number of Strings	4	8	12
Capacity(kWh)	1672	3344	5016
Nominal Voltage(V)	1331.2		
Operation Voltage Range(VDC)	1218.88~1476.8		
Discharge Depth	90% DoD		
Thermal Management Mode	Liquid-cooled		
Thermal Control Management	Aerosol Extinguishing or PFH		
AC Output			
Rated AC Output Power(kVA)	840	1670	2500
Max.AC Output Power(kVA)	860	1725	2580
Rated Output Voltage(VAC)	690		
Output Voltage Range(VAC)	690(-15%~10%)		
Rated Grid Frequency(Hz)	50/60		
AC PF	0.99/-1~1		
THDi	≤3%		
System Characteristic			
Communication Interface	CAN, RS485, Ethernet		
Warranty	5 years free, paid from the 6th to the 15th year		
Certifications	IEC62619, IEC62477, EN61000-6-2/4, UL9540A, UL9540, UN3536		
General Parameters			
Product Model	R-SM1672840A1-US	R-SM33441670A1-US	R-SM50162500A1-US
Dimensions - D*H (in)	96*102.1	96*102.1	96*102.1
Dimensions - W (in)	117.76	235.52	353.27
Battery System Total Weight (lb)	~33069	~66138	~99208
Operation Altitude	4000m / 13000feet (>3000m/10000feet derating)		
Nosie Level@1m	<75dB		
IP Rating	IP54		
Operation Temperature (°C/°F)	-20~55 / -4~131 (De-rating over 45°C / 113°F)		
Operation Humidity (RH)	≤95%, No condensation		
Storage Conditons	-20°C to 30°C, Up to 95% RH, non-condensing, State of Energy (SoE): 50% initial		

■ Combiner System Parameter

Product Parameter	
Input Voltage (VAC)	690V, 3W+PE
Access Channel	3
Output Channel	1
AC Output Power (kW)	2500
Max. AC Output Current (A)	2902
General Parameters	
Battery Model	R-SC2500ACC01-US
Dimensions - W*D*H (in)	~31.5*86.6*103
Total Weight (lb)	~1653.5
Communication Interface	RS485, CAN, LAN
Specifications Matched for Energy Storage Systems	1.67MWh ESS, Supports Parallel Connection of Up to 3 Units

EStand

Cabinet DC Fast Charging Solution

EStand is a high-performance energy storage solution for commercial and industrial use, featuring optimized thermal management, efficient energy cycling, advanced fire and gas detection, and intelligent power management for reliable and scalable energy integration.



Product Function



Stable & Reliable Performance

Featuring a 261kWh energy storage system, it delivers consistent power even during grid instability. An advanced thermal management system ensures efficient heat dissipation, enabling long-term stable operation.



Energy-Efficient & Eco-Friendly

High-efficiency power conversion minimizes energy loss and lowers costs. Compatible with solar, wind, and supports CCS1 plus NACS charging interfaces for versatile EV integration and sustainability.



Space-Saving Design

The dual-gun charger adopts a compact design that conserves installation space, making it ideal for various application scenarios including urban and commercial environments.



Intelligent Management System

Supports remote operation and real-time monitoring for easier maintenance and control. It also logs detailed charging data, helping operators optimize energy usage and refine charging strategies.



Enhanced User Experience

Designed with user convenience in mind, it features an intuitive interface and supports multiple payment methods. Built-in protections like over-voltage and over-current safeguards ensure a safe and reliable charging experience.



Cost-Effective Operation

Its high charging efficiency reduces power loss, improving overall energy utilization. Intelligent system control and optimized cooling also extend equipment lifespan, further reducing long-term operational costs.

Product Features

High-Power DC Fast Charging

Delivers up to 400kW for ultra-fast EV charging and supports dual-vehicle charging to improve efficiency and reduce wait times.

Comprehensive Safety Protection

Equipped with over-voltage, over-current, over-temperature, and short-circuit protection, plus insulation monitoring and emergency stop for maximum safety.

Integrated Energy Storage & Off-Grid Power

Features a 261kWh battery system that provides backup power during grid outages or peak hours, ensuring continuous charging even when off-grid.

Smart Data Tracking & Energy Analysis

Automatically records detailed charging data, including energy usage, duration, and cost, for both users and operators. It also offers energy consumption reports to help optimize the operation and efficiency of the charging station.

Application Scenario



Product Topology (DC Coupling)

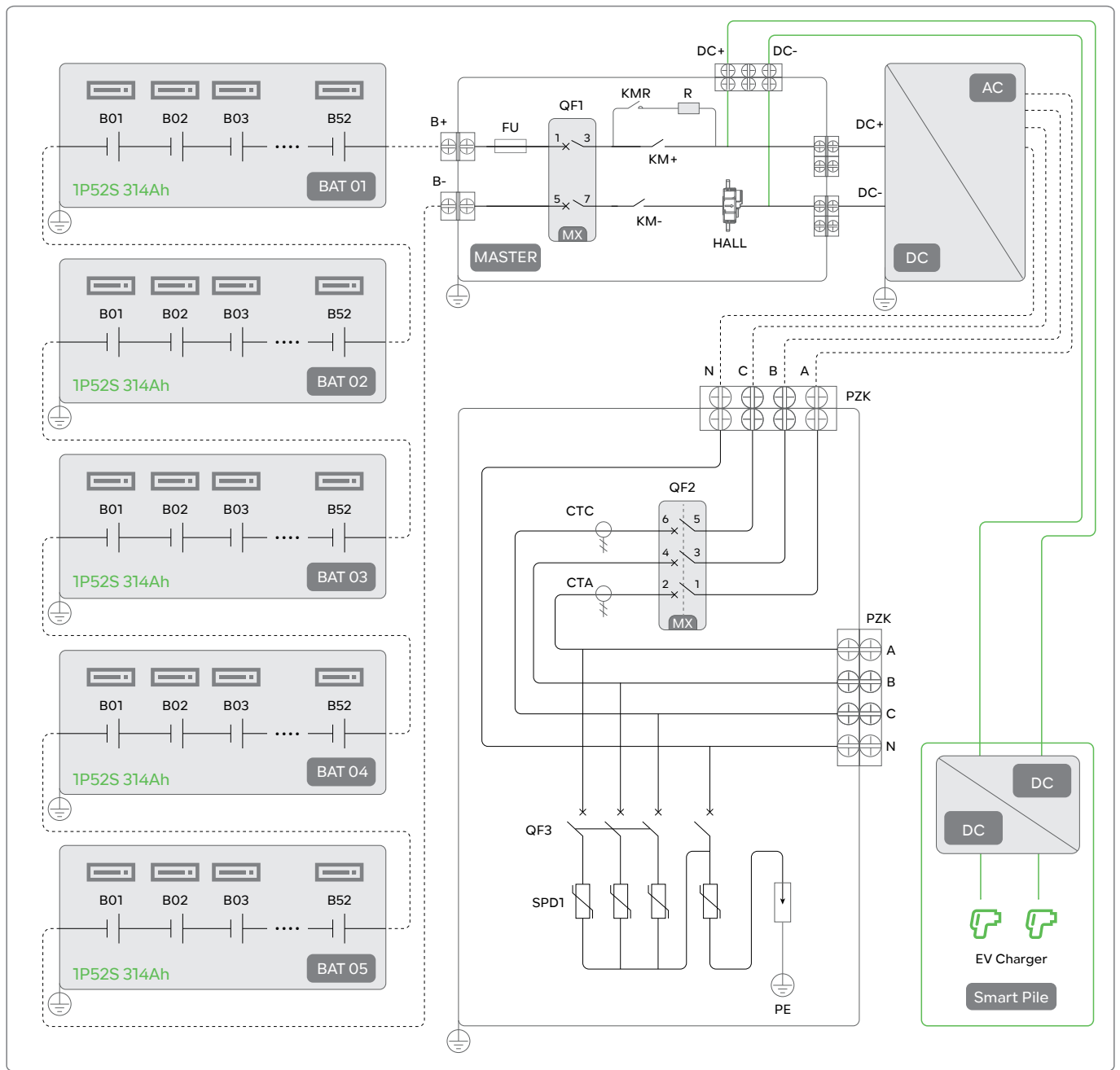

Packaging & Shipping Details

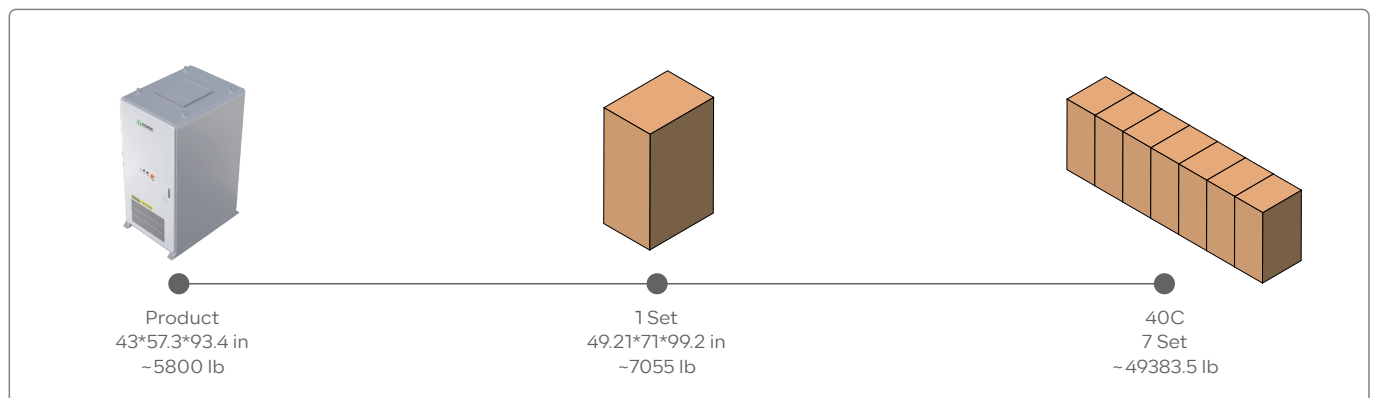

Product Topology(AC Coupling)

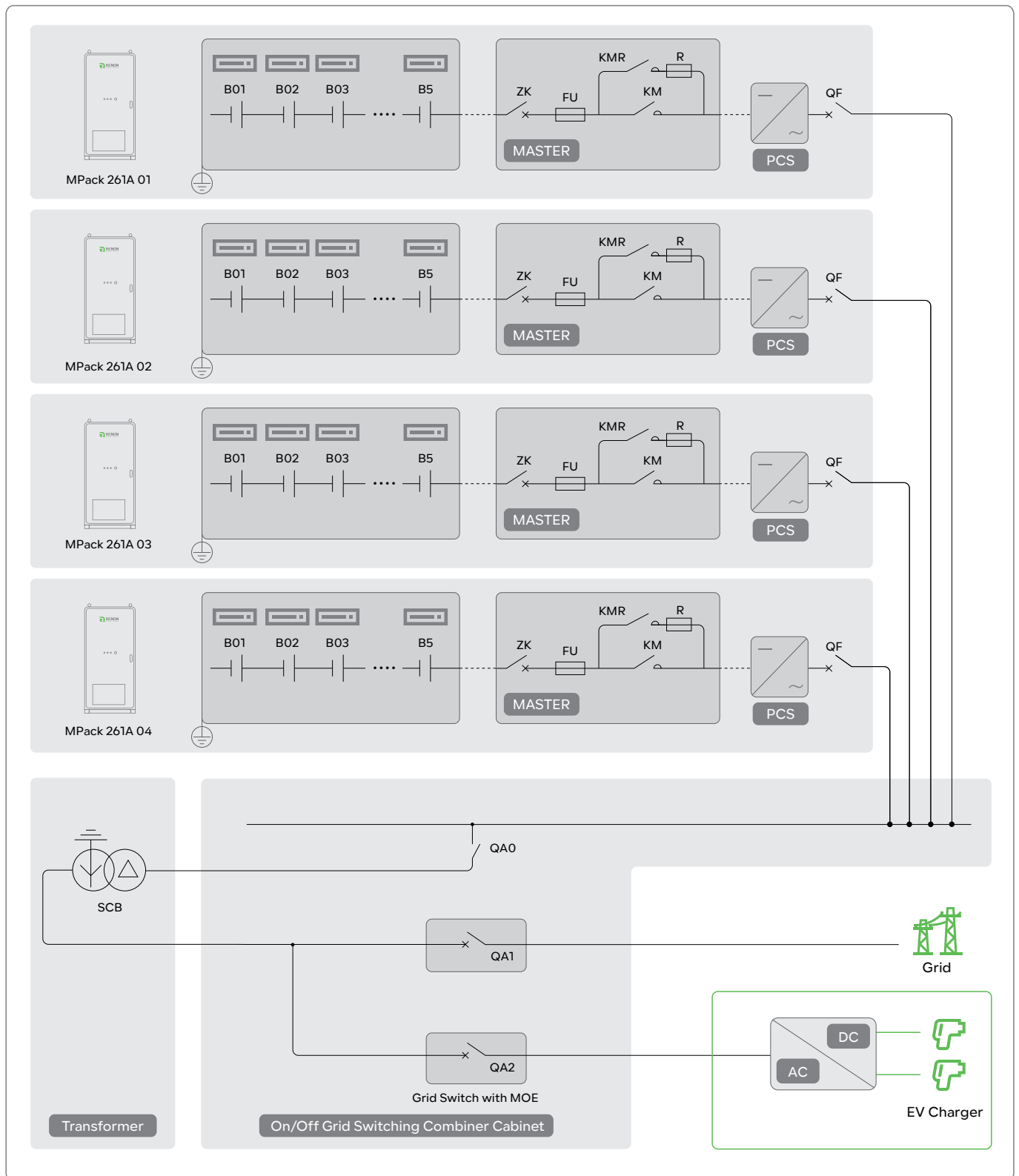

Single / Max. Parallel System Layout

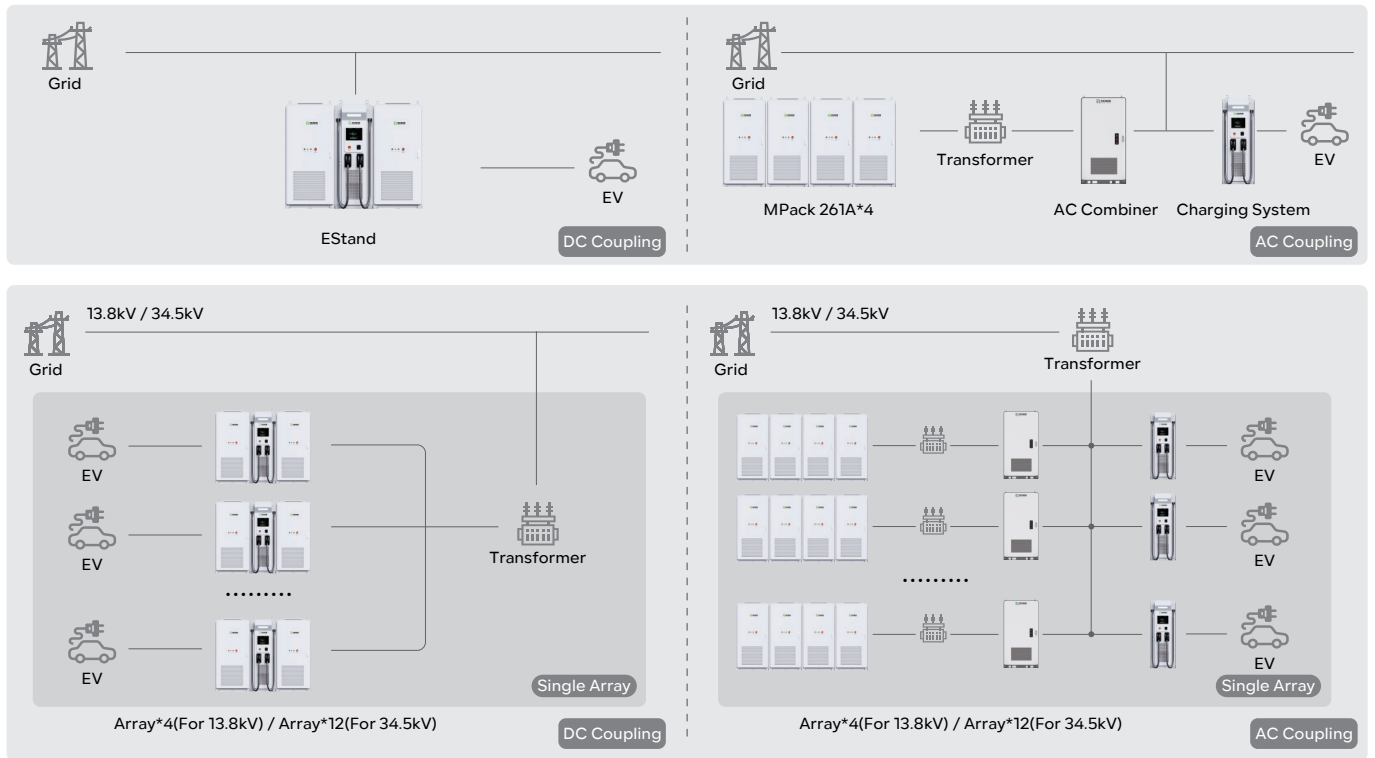

Energy Management System(EMS) Structure

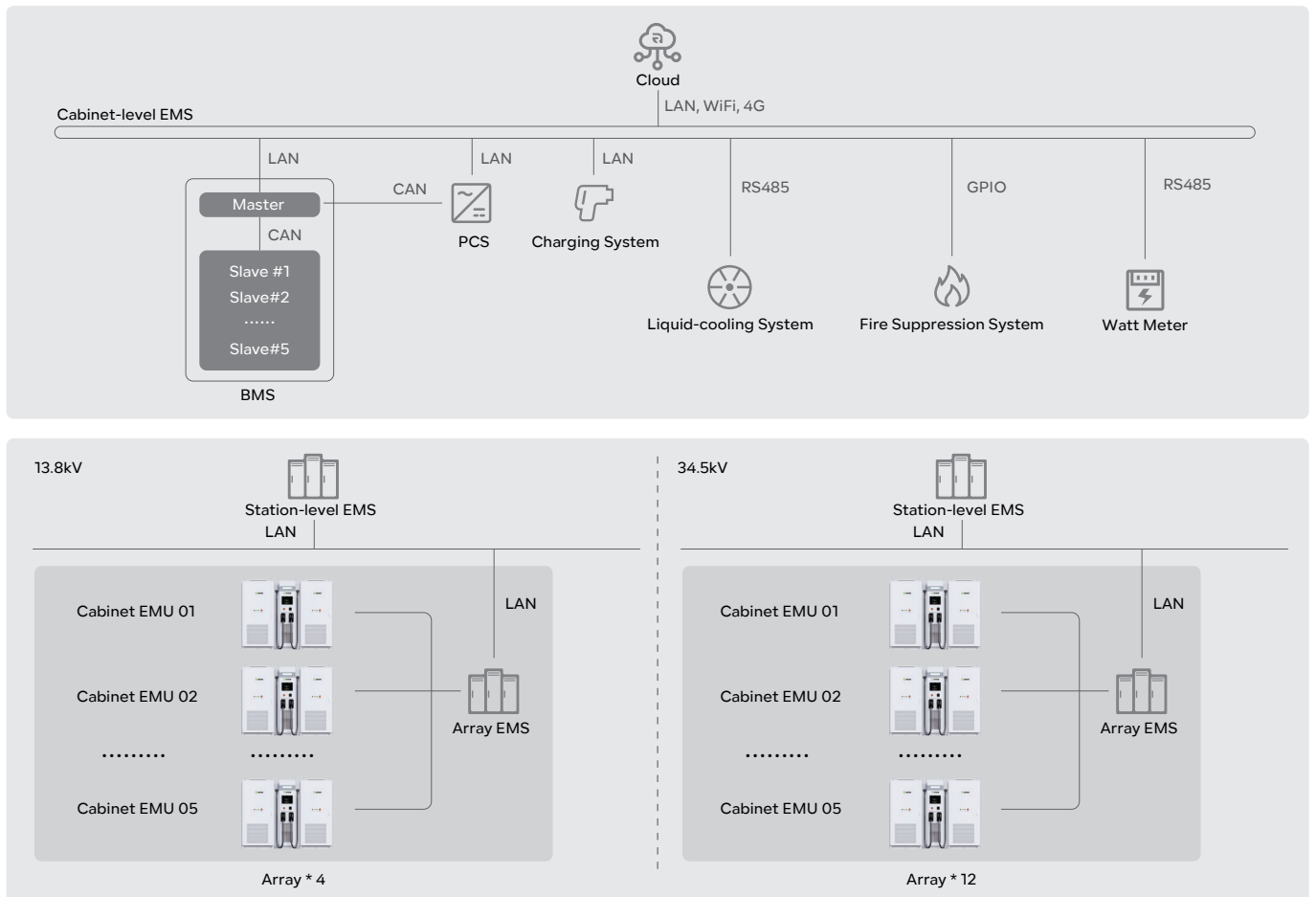

BESS Parameter

Battery Energy Storage				
Battery Capacity (kWh)	261	522	783	1044
Nominal Voltage (V)	832			
Operation Voltage Range (Vdc)	702~936			
Discharge Depth	90% DoD			
Thermal Management Mode	Liquid-cooled			
Thermal Control Management	Aerosol Extinguishing			
AC Output				
Rated AC Output Power (kW)	135	270	405	540
Max.AC Output Power (kVA)	148.5	297	445.5	594
Rated Output Voltage (VAC)	480			
Output Voltage Range (VAC)	408~528			
Rated Grid Frequency (Hz)	60(±5)			
Adjustable Power Factor	0.99/-1~1			
THDi	≤3%			
DC/DC				
Max. Charge/discharge Power (kW)	270	540	810	1080
Voltage Range for Charge/discharge (VDC)	761~923			
Max. Current (A)	314	628	942	1256
System Characteristic				
Communication Interface	CAN, RS485, WiFi, LTE			
Warranty	5 years free, paid from the 6th to the 15th year			
Certifications	ANSI/CAN/UL1973:2022,ANSI/CAN/UL9540:2020,UL9540A:2019, UL1741:2012 Ed.3+R:19May2023 UL1741:2021 Ed.3(Supplement SB),CSA C22.2#1071:2016 Ed.4+U1, IEEE 1547:2018,IEEE 15471:2020			
General Parameters				
Battery Model	R-ES261135C1-US	R-ES522270C1-US	R-ES783810C1-US	R-ES10441080C1-US
Dimensions - W*D*H (in)	~86*57*91.3	~129*57*91.3	~172*57*91.3	~215*57*91.3
Total Weight (lb)	8124(±11)	14429(±11)	20734(±11)	27039(±11)
Operation Altitude	≤4000m/13122ft (2000m/6561ft derating)			
Noise Level @1m	<75 dB(A)			
IP Rating	IP54			
Operating Temperature (°C/°F)	-20~55/-4~131			
Operating Humidity (RH)	0 to 95%, non-condensation			
Storage Conditions	-20~30°C/-4~86°F, Up to 95% RH, non-condensation, State of Energy (SoE): 50% initial			

■ Charging System Parameter

Power Output	
DC Voltage(VDC)	200~1000
Max. Current(A)	400
Max. Power(kW)	400
Efficiency	>97%
Voltage Stabilized Accuracy	≤±0.5%
Current Stabilized Accuracy	≤±1%
Current Sharing Unbalance	≤±3%
Peak-to-peak Ripple	≤1%
Structure Design	
Installation Method	Floor-stand
Charging Outlet	NACS, DC CCS1
Cable Length (ft)	16.4
LED Indicator	Yes
Authentication	RFD, On-screen PIN code authorization Option: payment terminal Autocharge Other Customization
Communication	
Charger v.s. EV	PLC(DIN 70121:2014-12/ISO15118)
Communication Protocol	OCPP 1.6J
Safety Protection	
Over/under Voltage Protection	Yes
Over Current Protection	Yes
Overload Protection	Yes
Short Circuit Protection	Yes
Leakage Protection	Yes
Over Temperature Protection	Yes
Grounding Protection	Yes
Integrated Surge Protection	Yes
General Parameters	
Battery Model	R-SP400C01-US
Dimensions - W*D*H (in)	~43.31*35.43*91.34
Total Weight (lb)	~1814.8
Operating Temperature (°C/°F)	-30~50/-22~122
Humidity (RH)	5%~95%, non-condensation
Operation Altitude	≤2000m/6561ft
IP Rating	IP55
IK Rating	IK10(HMI: IK08)
Application Site	Indoor/Outdoor
Cooling Method	Air-cooled
Noise	<80dB(Ambient Temperature)

XGen

Mobile Energy Storage Solution

XGen is a highly adaptable and energy-efficient portable power solution, offering multiple output options to ensure high performance, flexible operation modes, and broad compatibility across diverse applications.



Product Function



Power Generation & Storage for Max. Efficiency

No need for high-power generators—XGen intelligently balances PCS power and generation to reduce fuel consumption.



Versatile Compatibility for All Power Needs

Multiple voltage outputs (480V, 208V, 240V, 120V) for residential, commercial, and industrial use.



Flexible Power Modes for Any Scenario

With a large 522kWh capacity, it supports hybrid, off-grid, AC/DC coupling, and more, adapting seamlessly to diverse energy needs.



High-Power Output, Handles Heavy Loads with Ease

Delivers up to 324kW instant output, ensuring stable power supply for demanding applications.



Smart Management with Remote Control

Built-in EMS system enables real-time monitoring and remote control via Web & App for effortless operation.



All-in-One Charging Solution

Supports Combo fast charging, Type-C & Type-A ports, powering EVs, storage systems, and digital devices.

Product Features

Multi-Source Energy Input

Powered by a 522kWh LiFePO4 battery, supporting grid, diesel generators, and solar DC charging for seamless energy integration.

Optimized Generator Usage

Pairs with generators, reducing upfront investment, fuel consumption, and maintenance costs for smarter power solutions.

Portable Durability

Towable for rapid deployment, with IP54/NEMA 3R protection ensuring durability in harsh environments.

Smart Operation and Maintenance

Comes with a complete EMS that is easy to upgrade, featuring big data management checks, proactive handling, and intelligent SOC calibration to ensure optimal performance with zero downtime.

Application Scenario



Product Topology

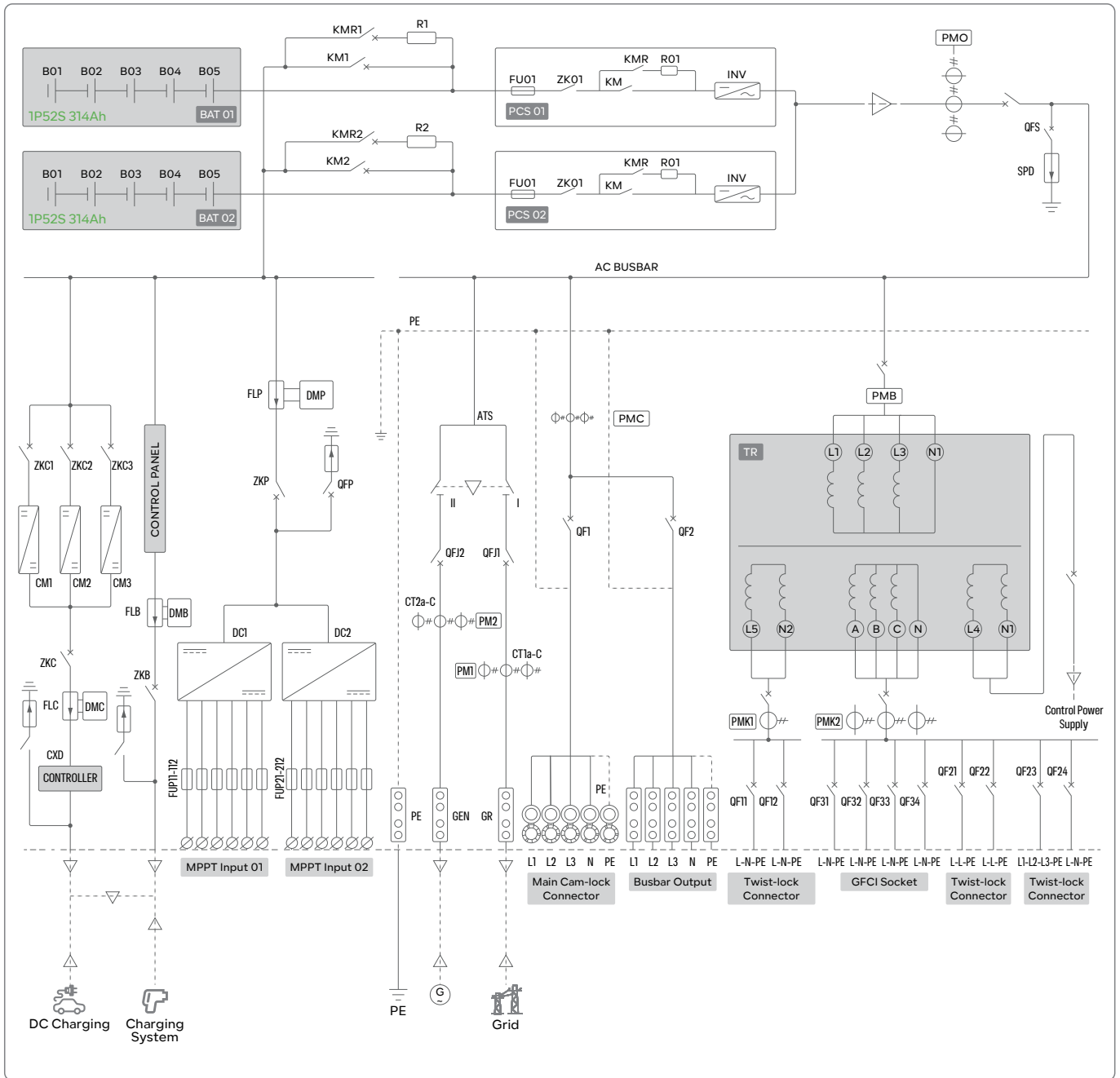

System Layout

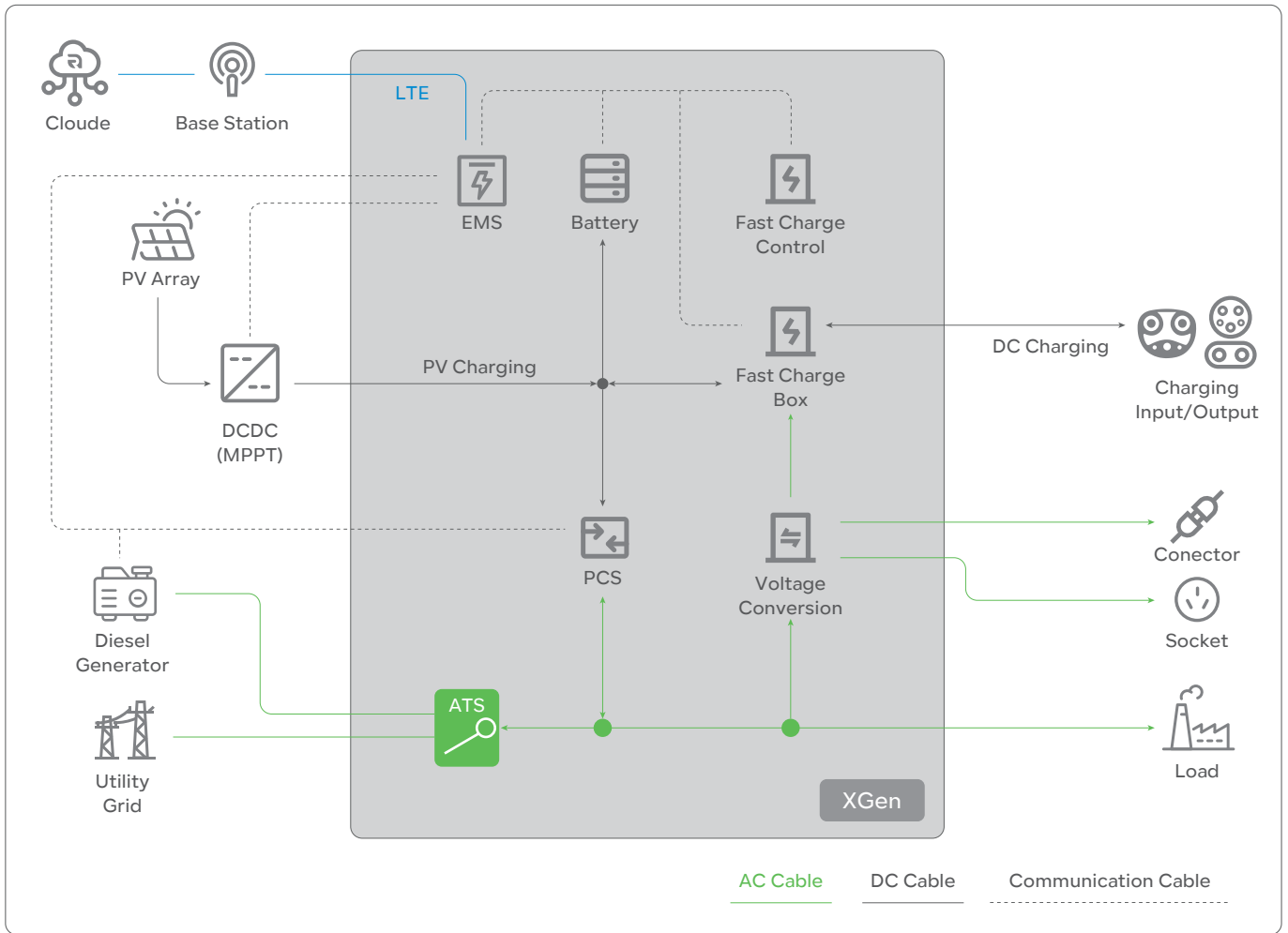

System Interface

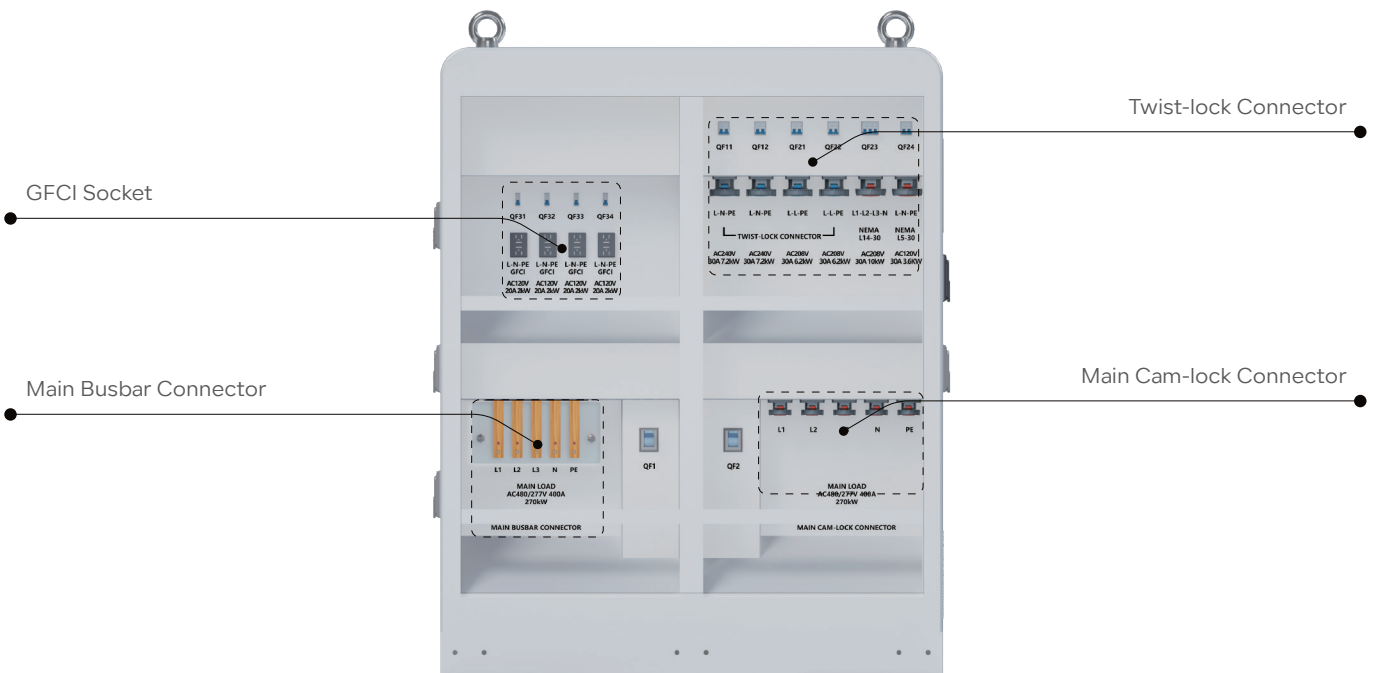

Product Parameter

Battery Energy Storage	
Cell Chemistry	LiFePO4
Nominal Energy (kWh)	522
Voltage Range (VDC)	702-936
Nominal Charging Current (A)	314
Nominal Discharging Current (A)	314
DOD	90%

AC 1: Output (480Vac On/OFF-Grid)	
Rated Power (kVA)	270
Rated Voltage (VAC)	480 (-15%~15%)
Frequency (Hz)	60 (-5~5)
AC Connection	3P4W(L1/L2/L3/N)
THDi	≤ 3%
Voltage Ripple Coefficient	≤ 1%
Power Factor	0.99/-1~1

AC2: Output (208Vac Output)	
Rated Power(kVA)	35
Rated Voltage(Vac)	208
Frequency(Hz)	60 (-5-5)
AC Connection	3P4W(L1/L2/L3/N)

AC3: Output (240Vac Output)	
Rated Power(kVA)	24
Rated Voltage(Vac)	240
Frequency(Hz)	60 (-5-5)
AC Connection	2P3W(L/L/PE)

AC4: Output (120Vac Output)	
Rated Power(kVA)	12
Rated Voltage(Vac)	120
Frequency(Hz)	60 (-5-5)
AC Connection	1P2W(L/N/PE)

*The total output power of AC is 270 kW. (AC1+AC2+AC3+AC4=270kW, AC2+AC3+AC4=35kW)
270 kW is available at 480 V 3-phase (main bus via PCS),
while the 208/240/120 V auxiliary ports are limited by the transformer to their listed kVA

PV Input	
Input Power (kW)	120
Input Voltage Ronger (VDC)	200-900 (575-900 @full load)
Number of MPPT	6
Max. Input Current of each MPPT (A)	35

EV Charging & Charging ESS (DC Charging)	
Interface Type	NACS, Combo CCS1 (SAEJ1772 Combo)
Rated Power(kW)	120
Output Voltage(to EV)(VDC)	200-1000
Input Voltage(to ESS)(VDC)	702-936

Compatible Diesel Generator	
Rated Power (kVA)	≤400
Rated Voltage (Vac)	480
Rated Frequency (Hz)	60

General Parameters	
Product Model	R-XG522270H1-US03
Parallel Capable	Yes (Up to 6)
Ingress Rating	IP54 / NEMA 3R
Working Temperature (°F/°C)	-4-131 / -20-55
Storage Temperature (°F/°C)	-40-149 / -40-65
Relative Humidity	5~ 95% (No condensing)
System Noise (dB)	<75
Thermal Management Mode	Liquid-cooled
Fire Suppression System	Included
Altitude(m)	5,000(>3,000 derating)
Certifications	UL1973, UL9540, UL9540A, UL1741, UL9741 UL2202(UL2231-1, UL 2231-2)UL991, UL1998
Dimensions - W*D*H (mm/in)	1720*3500*2155 / 68*138*85
Weight (kg/lb)	5800 / 12,786.8
Corrosion Class	C5

ProControl Base

Cabinet Level Local ESMU

High-end integrated display and control system for commercial and industrial energy storage solutions.



Features



High-Performance Data Processing MCU

Equipped with a powerful processor and ample memory, ensuring fast response to demand-side instructions and efficient data processing.



Advanced Graphics and AI Capabilities

Featuring advanced graphics processing and AI capabilities, offering robust performance for enhanced device intelligence.



High-Brightness Full-View Touch Display

1280*800 resolution, 45cd/m² brightness, full viewing angle, and three-point capacitive touch screen, allowing easy viewing of system data and settings both indoors and outdoors.



Independent Smart Local Control

Built-in modes such as self-use, peak shaving, PV priority, grid priority, backup, and battery modes provide convenient local operation. Supports local intelligent monitoring, data curve generation, parameter settings, firmware updates, maintenance report generation, and log recording for simplified after-sales service.



Flexible Cloud Connectivity

Supports multiple interfaces including LAN, WiFi, and LTE for versatile cloud platform connections based on customer needs.



Comprehensive Communication & Control Interfaces

Includes CAN, RS485, RS232, Type-C, USB3.0, LAN, TF card slot, Nano SIM, HDMI, and RTC interfaces, enabling connection to various external devices and sensors for centralized management and control.

Interface Showcase

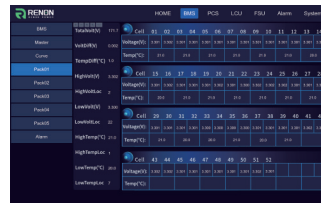

Parameters

General Parameters

CPU	RK3568 4xA53@2.0GHz
Memory	RAM: 4GB, EMMC: 64GB, EEPROM:64KB, SSD: 1T(Optional)
GPU	Mail-G52
NPU	Support 1 Tops computing power
OS	Ubuntu 20.04
Brightness	450cd/m ²
Resolution	1280*800
Angle	Full viewing Angle
Touch	3 point capacitive screen
Communication interface	3* CAN, 6* RS485, 1*RS232, 1*Type-C, 1* USB3.0, 4* 1000Mbps, Lan, 1* TF card, 1* Nano SIM card, 1* HDMI, 1* RTC
Control interface	12* DO, 16* DI, 2* NTC, 1* Buzzer
Wireless communication	WiFi/BT, 4G, GPS
IP Rating	IP65
Operating temperature (°C/°F)	-20~70/-4~158

ProControl Prime

Station Level Local EMS

Reliable control and display solution for large distributed energy storage systems.



Features



Information Summarization and Monitoring

EMS collects and uploads operational data of distributed energy storage systems for centralized monitoring. It displays system trends, performance metrics, and fault history to help users optimize operations.



Strategy Algorithm Configuration

EMS offers flexible strategy algorithms for customizing energy storage system operations based on specific needs and system conditions. This allows for optimal energy dispatch and management to maximize efficiency and cost-effectiveness.



Alarm Generation and Handling

EMS provides a user-friendly tool for creating graphical interfaces of energy storage systems. It allows real-time monitoring and management through topology, status diagrams, and device controls.



Energy Metering and Anti-Reverse Flow Control

EMS handles energy metering and anti-reverse flow control, effectively managing energy flow within the storage system and ensuring stable PCS operation.



BMS Data Collection and Display

EMS communicates with Battery Management Systems (BMS) to collect real-time data on battery parameters and displays it graphically. This includes battery health, charge/discharge status, SOC, and SOH.



Profit Analysis

EMS includes robust profit analysis capabilities for in-depth assessment of energy storage system operational data. This analysis helps users evaluate economic benefits, providing strong support for decision-making.

Interface Showcase

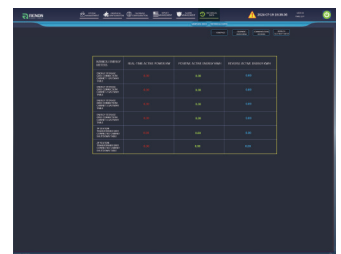
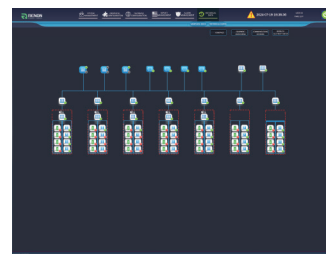
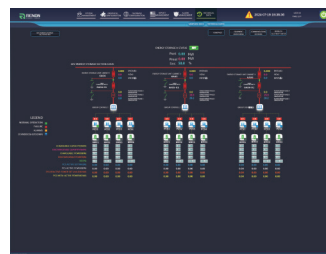

Parameters

General Parameters

CPU	2U Rack Server
Memory	Intel® Xeon® Gold 5218 Processor 22M Cache, 2.30 GHz, Qty 2
Hard disk capacity	64GB
NIC	3*1.2T SAS
PCIE	4 Gigabit LAN cards 6 PCIe 3.0
Power Supply	slots 550W power supply*2
Chassis Size	Chassis Specifications: 445*87*746mm
IP Rating	IP20
Operating Temperature (°C/°F)	5~40/41~104
Operating Humidity	85% RH

Renon Smart

Cloud Energy Management System

We're Using Smart Power to Simplify Your Life.

Renon Smart is a comprehensive device management and monitoring solution for national agents, secondary agents, installers and users. Comprehensive system for managing large-scale power station and commercial and industrial energy storage systems



Features



Instant Clarity with Remote Data Monitoring and Analysis

Remote data monitoring, automatic curve generation, and big data analysis management make the product operation status clear at a glance.



Enhanced Security with Distributed Architecture and Data Encryption

Distributed architecture deployment and data security encryption ensure that cloud data is more secure and reliable.



Seamless Connections with Intelligent Mall and Trial Applications

Intelligent mall application and new product trial application enable users to contact source manufacturers directly, making product promotion faster and more accurate.



Boost Customer Satisfaction with Remote Firmware Upgrades

Remote firmware upgrading and intelligent operation and maintenance report generation effectively improve customer satisfaction.



Optimized Channel Construction with a Six-Level Distribution System

The six-level distribution system, from the brand owner to end-users, is more conducive to robust product channel construction.

Interface Showcase

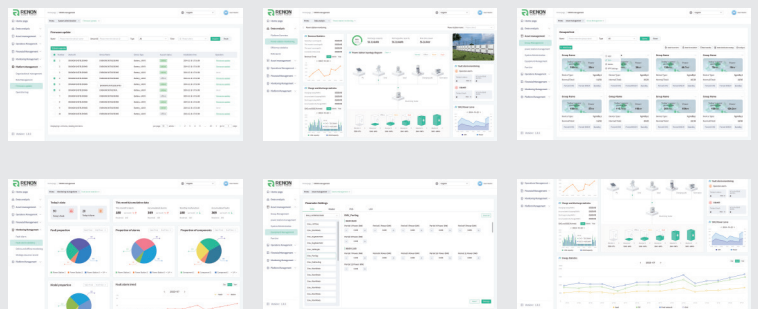

Physical Link

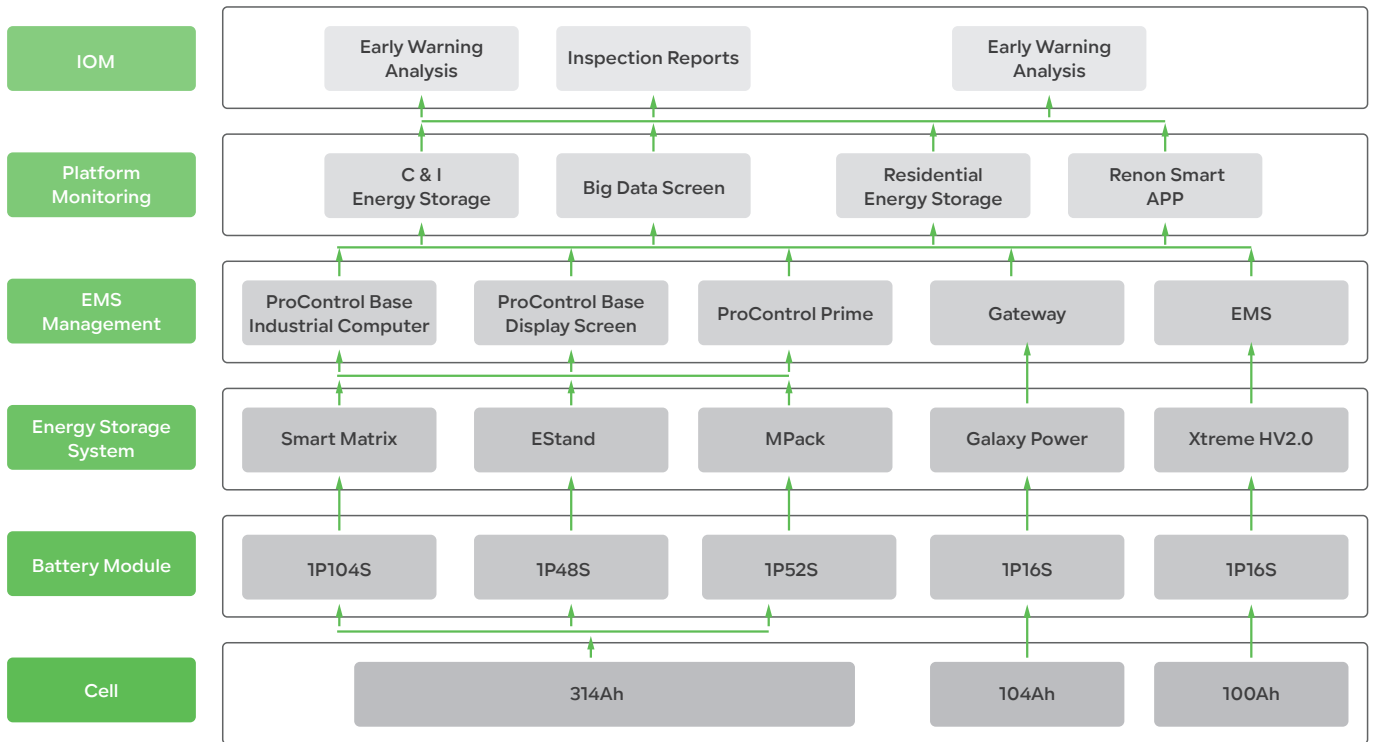

Platform Architecture

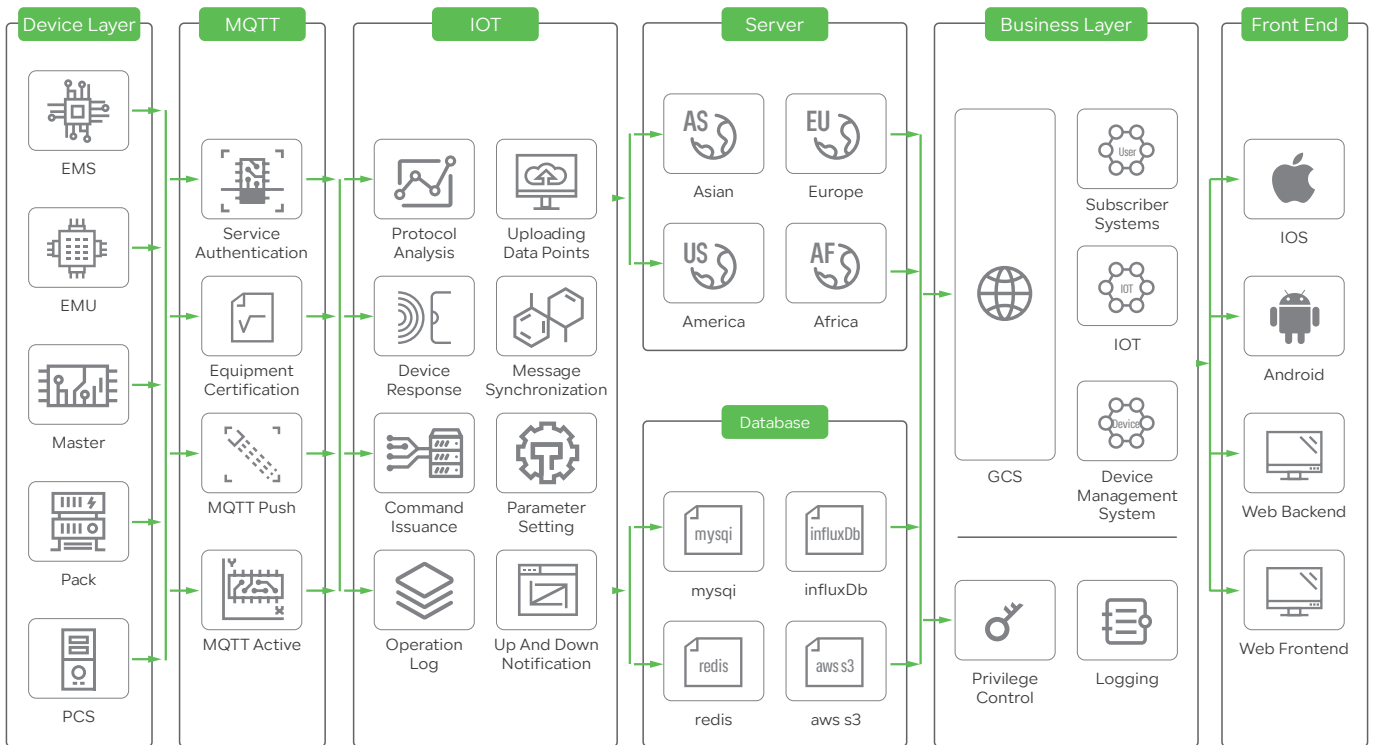

Installation Cases

Renon Power's global installations of microgrid systems enhance energy efficiency and sustainability, providing reliable power solutions for diverse commercial and industrial applications.



Renon EStation 430A

Japan



MPack 233A*5

Austria



MPack 233A*2

United States



ECube 60AP*2

Netherlands



ECube 215D*9

Japan



MPack 233A

United States



ECube 60AP*2

The United States



ECube 60AP*2

Netherlands

Renon Exhibition



At Renon Power, our team is our greatest asset.

We are a diverse group of passionate professionals, united by a shared mission to make green power within reach.

RE+ 2025

United States



Intersolar 2025 Europe

Germany



RIMINI Expo

Italy

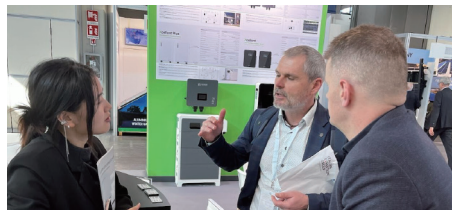

Intersolar 2025 San Diego

United States



PV EXPO 2025 Tokyo

Japan



Renon Power USA LLC

580 McIntyre Rd. McKinney, TX 75071

Renon Power Technology B.V.

Rietbaan 10, 2908 LP Capelle aan den IJssel

Renon Power 株式会社

東京都中央区日本橋箱崎町 20-5 VORT 箱崎 5F



LinkedIn



Website